

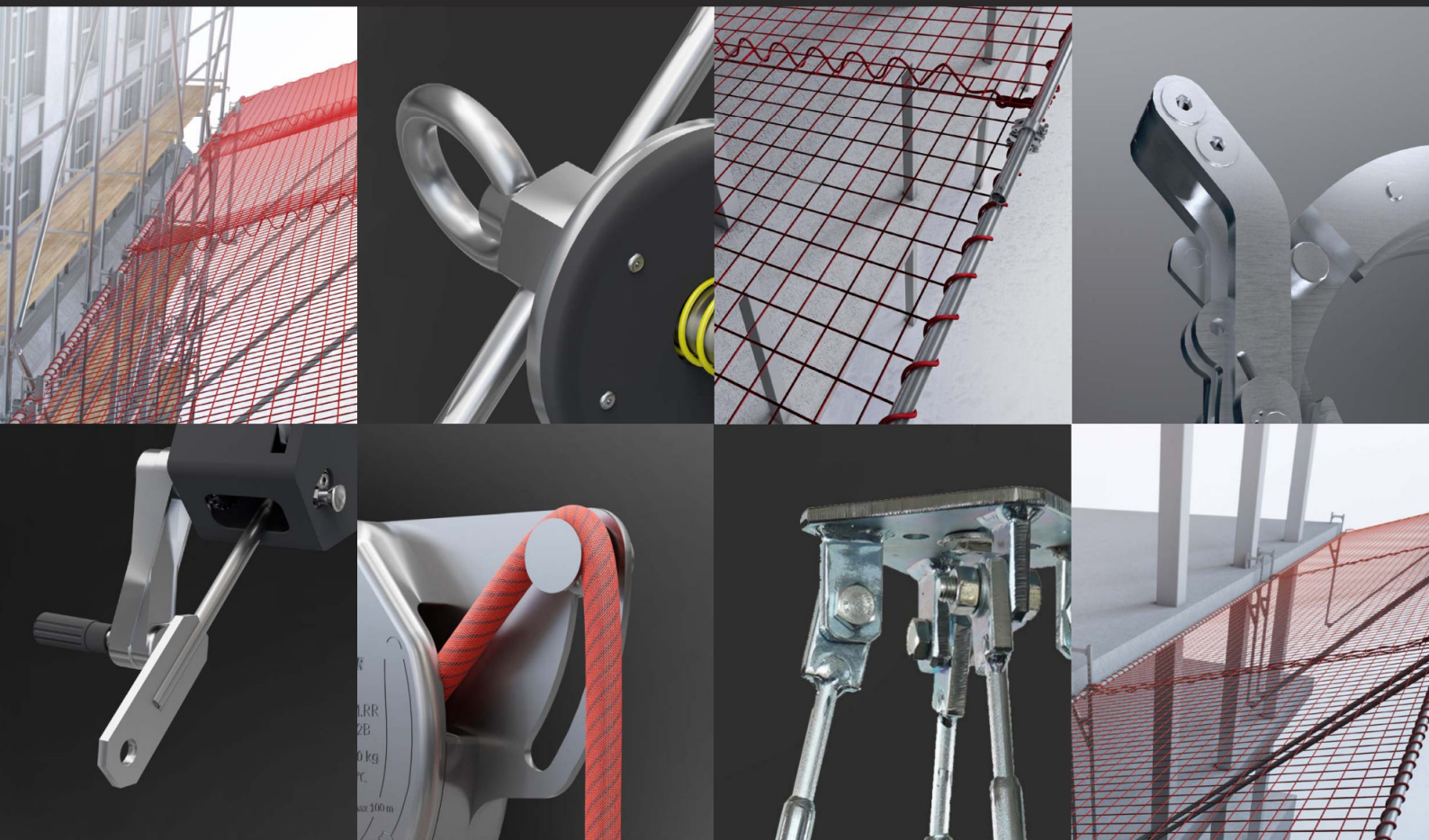

INNOVATIVE PRODUCTS

For Construction Industry



ROCK MASTER

SOLUTIONS FOR THE CONSTRUCTION INDUSTRY

Rock Master has been operating in the construction industry as an expert in fall protection since 2007; the company has provided services to such clients as Skanska, Budimex, Strabag.

To date, we have carried out our mission by conducting audits at construction sites and by providing consulting, training both workers and supervisory staff, as well as by supplying standard protection equipment (both individual and collective).

In 2023, Rock Master has successfully launched a project aimed at developing innovative equipment to improve the safety of construction workers.

Through many years of cooperation with the construction industry, we have identified needs and created devices to address problems for which no solutions were offered before.

These include:

- An access system for multi-storey storage containers to allow safe climbing regardless of the number of levels.
- A safe access system for wall formwork that effectively protects the workers against falls even while performing the most unusual types of tasks.
- An access system for aluminum type scaffolding towers; quick and easy to install.
- A safe access and edge work system for all flat surfaces; the system is effective even for overpasses formworked with plywood.
- A T-system that can be attached to scaffolding, columns and ceilings.
- A custom two-piece fall arrest harness for construction workers: ergonomic, pressure-free, lightweight and allowing for the integration of work clothes or hi-vis vests.

Each of our devices has an instructional video. They can also be tested in our VR training. More information can be found in the VR Catalog available at: www.rockmaster.eu



TABLE OF CONTENTS:

CAS - CONTAINER ACCESS SYSTEM	4
NPK - CORNER ANCHOR POINT	7
HAWP - SHORING SCAFFOLD SAFETY HOOK	10
HAS - FORMWORK HOOK	13
SAS - FORMWORK SAFETY POST	16
SCAFFOLDING SYSTEM T SAFETY NET /STWR/	19
PILLAR TYPE T SAFETY NET /STWP/	22
FLOOR TYPE T SAFETY NET /STWS/	25
BUILD MASTER - FALL ARREST HARNESS	28
UZO - DESCENT & RESCUE DEVICE	31
PSA - HORIZONTAL SAFETY SYSTEM	34
QUADPOD - ANCHOR POST FOR WOODEN CEILING FORMWORK	37

**CAS
CONTAINER
ACCESS SYSTEM**



CAS - CONTAINER ACCESS SYSTEM

LADDER INTEGRATED WITH ANCHOR LINE TO BE MOUNTED TO CONTAINER CASTINGS

CHARACTERISTICS

Container access system consists modular ladders which are meant to be mounted into holes of container castings. Modular ladder is integrated with vertical anchor line, anchor points and exiting post. All these elements provide continuity of protection while moving on different levels of construction containers.

System was designed in conformance with EN795B and DIN18799-2 standards.

Thanks to their modularity ladders can be connected with each other to give protection on a multistore construction sites. Intermediate anchor points (mounted to side holes of container castings) provides further support when climbing and installing following modules.

Upper module is meant to be installed on a top container, and is designed to be used with exiting post.

Exiting post can be used as a separate anchor point or as a part of horizontal lifeline (lifeline installed between two exiting posts) to give protection during work on a roof of container.

Rungs and main rail are made of aluminium to save weight. Because of their lightness modular ladders are convenient to use and do not require any winch or crane to mount them.

Mounts ensure perfect fitment to the container castings. After inserting locking part of the mount in a hole of a casting you will only need to rotate locking mechanism 90 degrees. Positioning and locking does not require climbing on the ladder. It is performed by pulling pilot wire which rotates locking mechanism in place. After positioning mount has to be tightened by turning lever.

Vertical anchor line is a 8 mm and it can be used with any fall arrester. Both intermediate and ladder anchor points can be used to work on height and to install following modules.

Neck in exit post helps to dissipate energy when fall occurs. It protects both worker and construction. We performed internal tests of the system and we are waiting for certification process.



PATENTED

TECHNICAL INFO

STANDARD:

DIN18799-2
EN795B

MATERIAL:

aluminium,
steel, rubber

**PACKAGE
DIMENSIONS:**

2,8x0,4x0,25m – lower mod.
3,2x0,4x0,25m – upper mod.
1,2x0,3x0,05m – exit post

WEIGHT:

18 kg – lower mod.
19 kg – upper mod.
4,5 kg – exit post

OTHER:

compatible
with TRACKER

Top view



1 Exit post anchor point

Side view

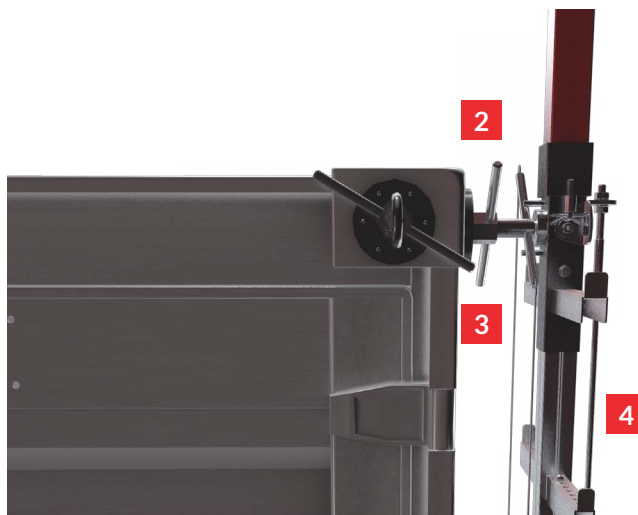

2 Ladder mount with locking mechanism

3 Pilot line

4 Vertical anchor line

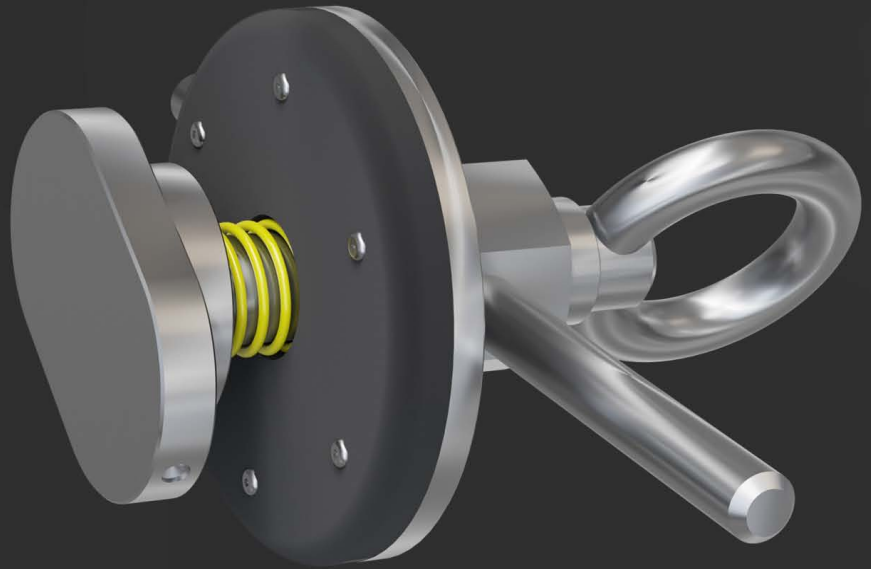
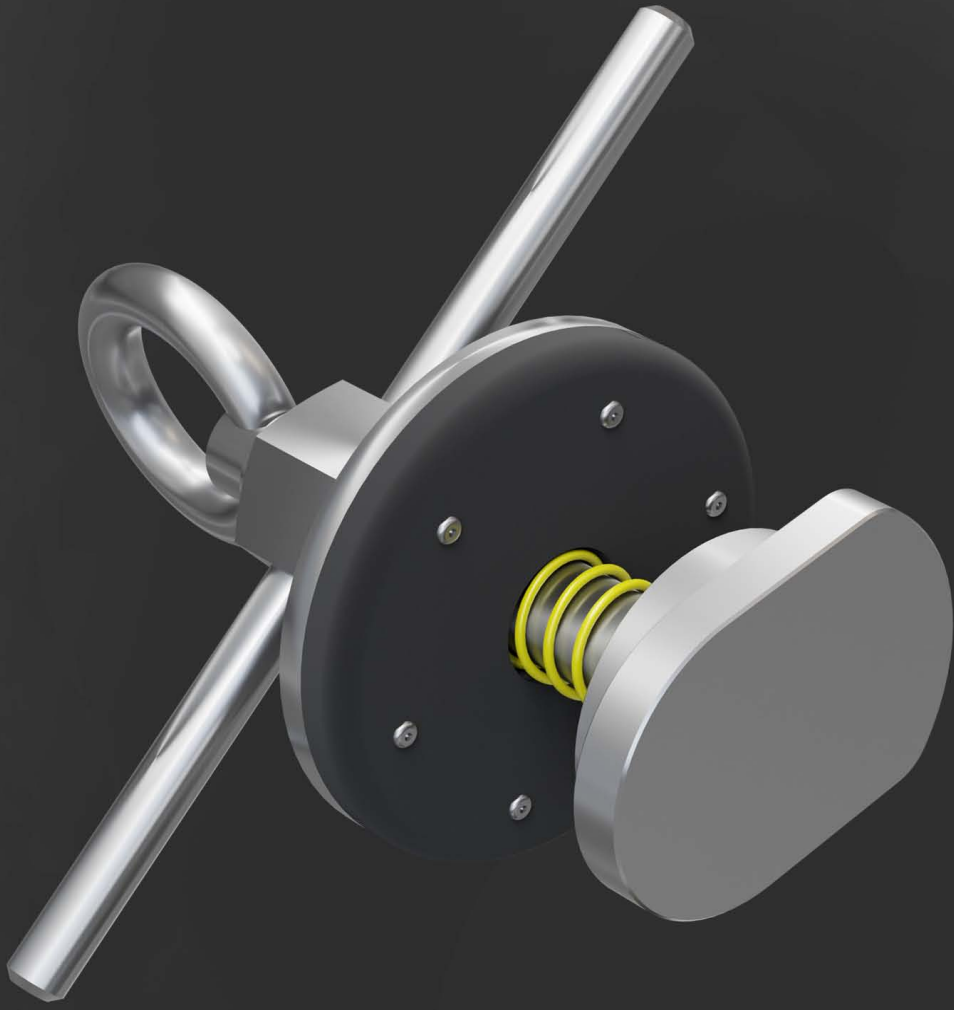

**NPK
CORNER ANCHOR POINT**

NPK

CORNER ANCHOR POINTS NPK_L, NPK_T



KEY FEATURES

The device is designed to protect the worker during the moving and handling of shipping and construction containers

The device complies with PN-EN 795B:2012, which means that it is a temporary anchor point installed in a way that prevents accidental disconnection of the point from the structural element to which it is mounted. However, it is possible to disconnect them intentionally from the structure; in this case, at least two separate and consecutive actions without the use of additional tools shall be performed.



PATENTED

Corner anchor points are available in two versions: NPK_L and NPK_T. The anchor points are designed to be installed in the transport slots located at the corners of the container.

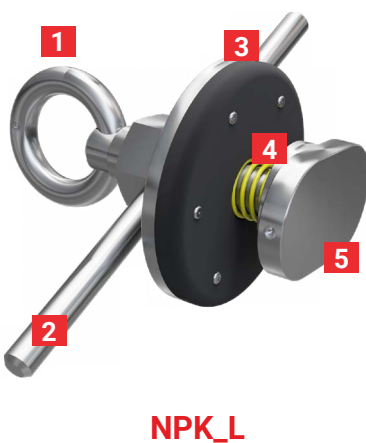
The corner anchor points are designed to be installed only in the side slots of container corners that comply with ISO 1161.

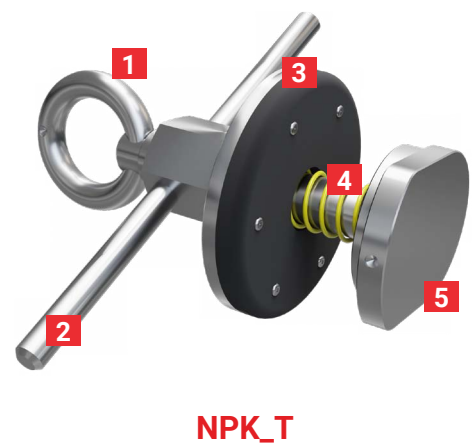

- 1** Eye of the anchor point
- 2** Pressure nut
- 3** Rubber washer
- 4** Extension spring
- 5** Lock



TECHNICAL FEATURES

STANDARD:	PN-EN 795:2012 typ B	TYPES AVAILABLE:	NPK_L, NPK_T	RISK CATEGORY: III
SAFE WORKING LOAD:	100 kg	MAX. NO. OF USERS:	1 person	

TYPES AVAILABLE

Since the slots at container corners come in different shapes, two different versions of the corner anchor point have been developed.



NPK_L - for oval slots.



NPK_T - for shield-shaped slots.



INSTALLATION

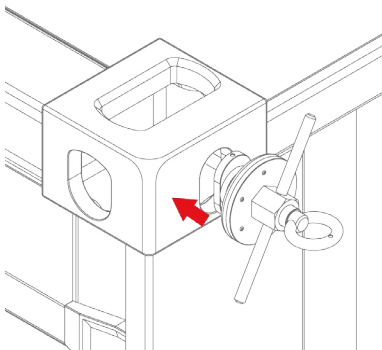

Place the lock of the NPK_L in the oval slot of the container corner.

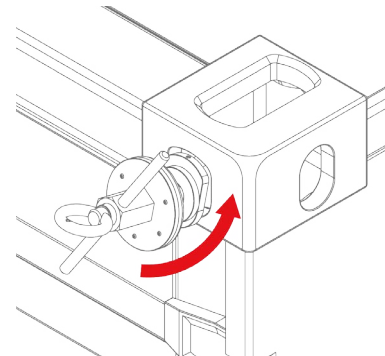
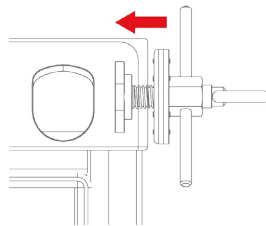

Place the lock of the NPK_T in the shield-shaped slot of the container corner.

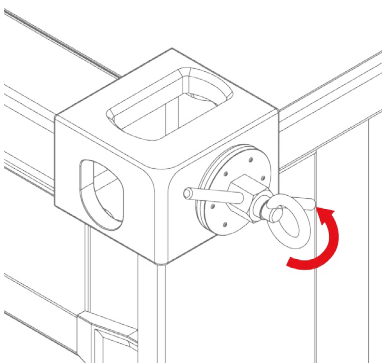
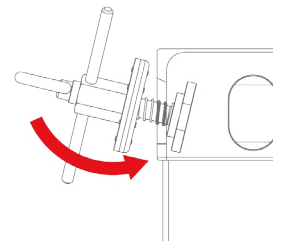

Turn the eye of the NPK to lock the anchor in the slot.

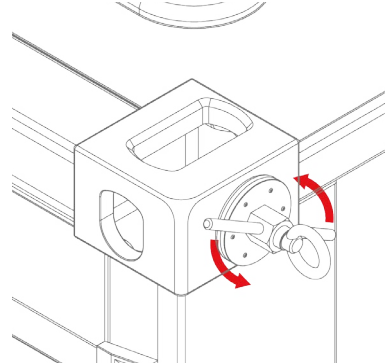
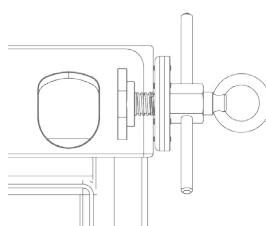

Tighten the pressure nut of the NPK.

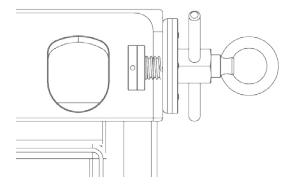

**HAWP
SHORING SCAFFOLD
SAFETY HOOK**



HAWP - SHORING SCAFFOLD SAFETY HOOK

MOBILE ANCHOR POINT FOR SHORING TOWERS

CHARACTERISTICS

Shoring Scaffold Safety Hook / HAWP / is a personal fall protection device conforming to EN795B standard.

HAWP is a mobile anchor point providing fall protection for workers during their operations on shoring towers. It is available in two versions: small for diameters (and profiles) ranging from 48 to 80 mm, and large for 100 to 120 mm.

Attachment point is located in a spot which allows for easy connection with safety lanyard.

Eccentric lever provides tight fit of the hook onto a shoring prop. Ratchet mechanism requires two, sequential operations to open and dismount a hook, therefore it protects from unintentional dismantling.

Elastomer inserts enhance fitment and protect from slippage.



Because of its self-tightening abilities it can be used when moving vertically and diagonally. It can be also used in a same way as a conventional connector (for climbing ladders etc.)

HAWP is patented by European Patent Office and will be certified by PRS.

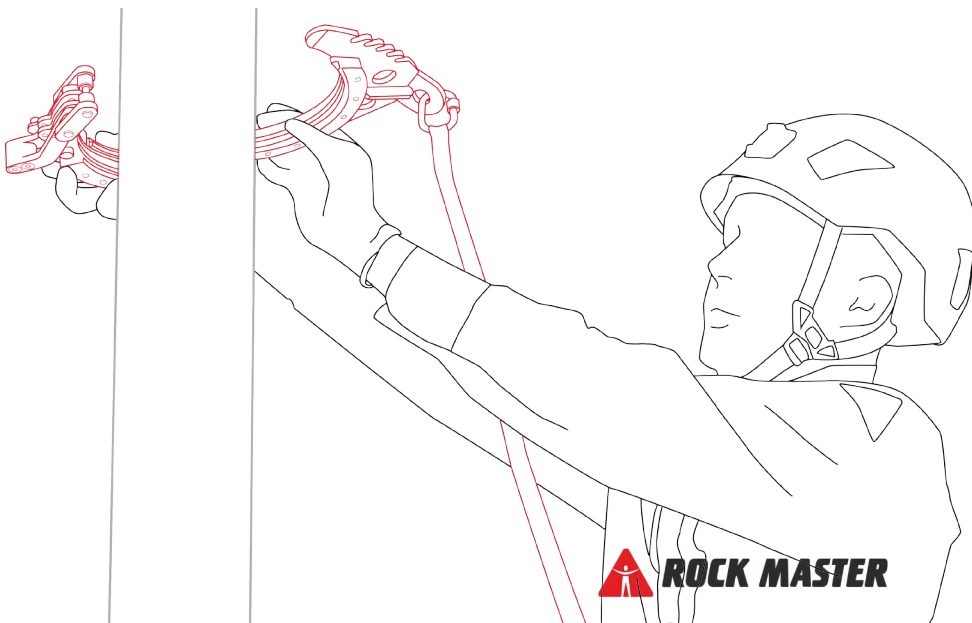

HAWP can be used on vertical, horizontal and diagonal construction elements.

TECHNICAL INFO

STANDARD: EN795B

MATERIAL:

stainless steel, aluminium,
silicone rubber

WEIGHT: S: 1,1 kg
L: 1,7 kg

**PACKAGE
DIMENSIONS:**

S: 20x15x5 cm
L: 25x20x5 cm

1 Ratchet mechanism

2 Eccentric lever

3 Pivot

4 Attachment point

5 Tooth part of a locking
mechanism



Ratchet mechanism allow for better fitment onto different profiles of shoring props. Silicone rubber inserts provides better grip and protect shoring from damage.

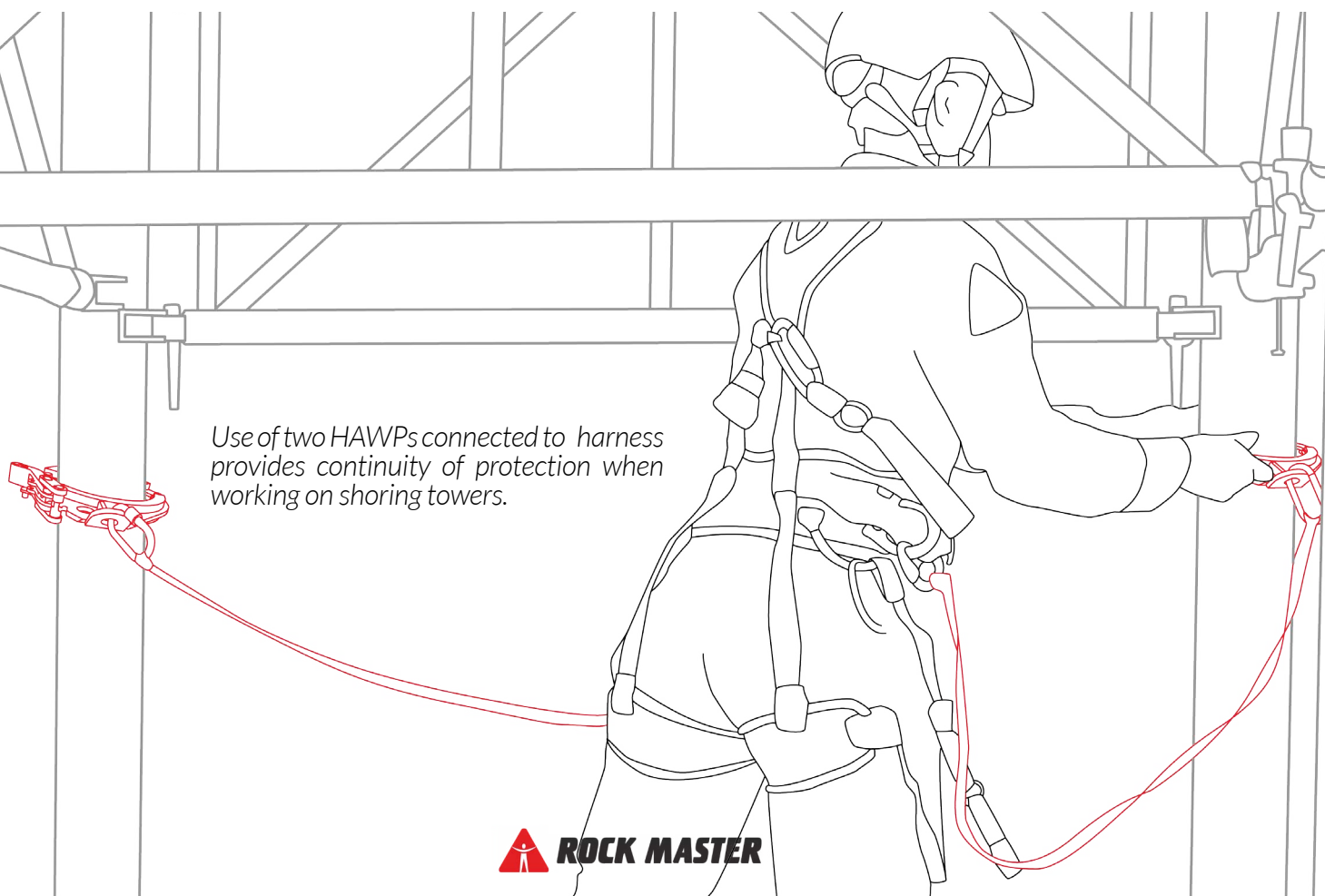

Use of two HAWPs connected to harness provides continuity of protection when working on shoring towers.

HAS FORMWORK HOOK

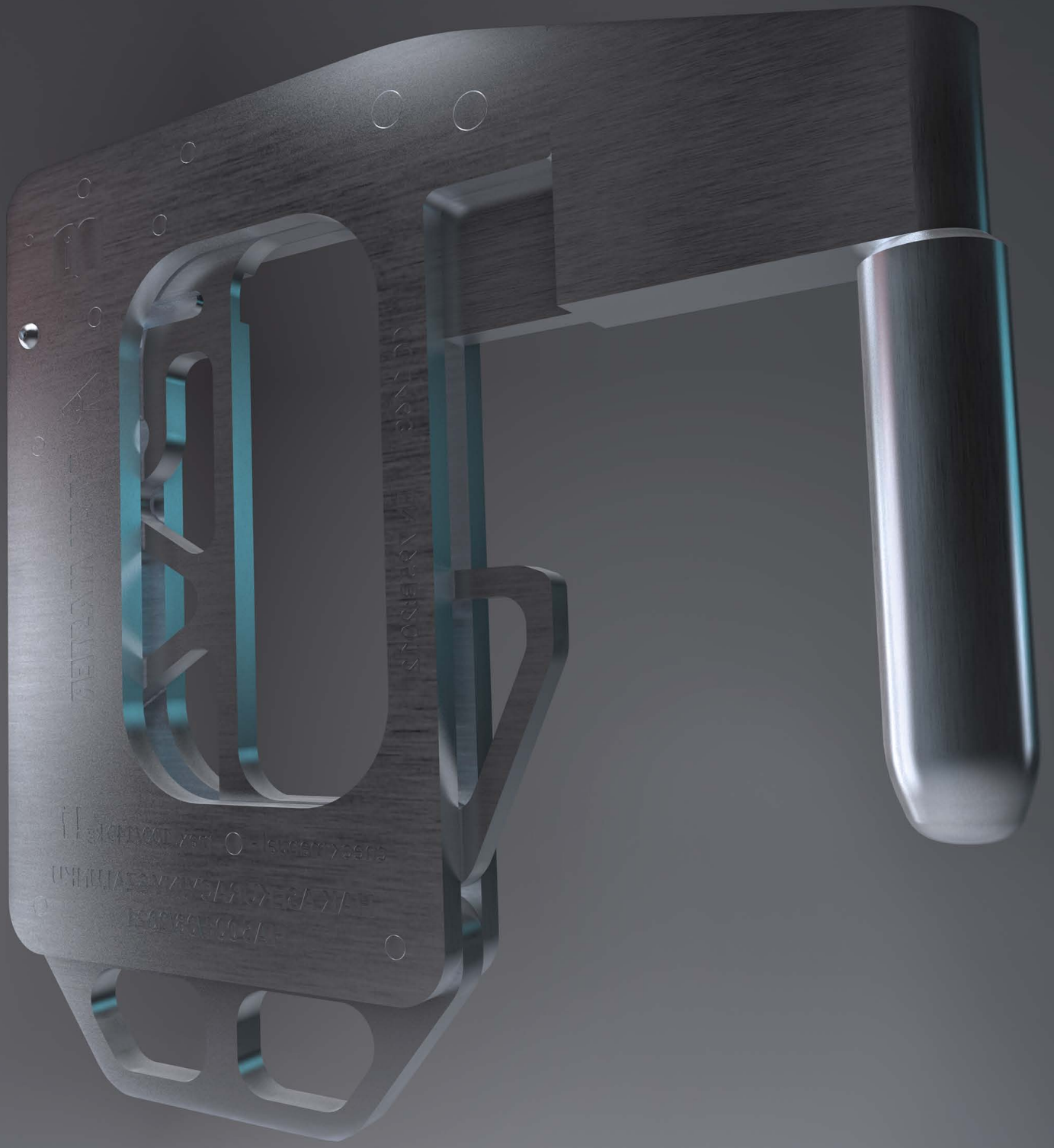

HAS - FORMWORK HOOK

HOOK PROVIDING FALL PROTECTION DURING WORK ON FORMWORKS

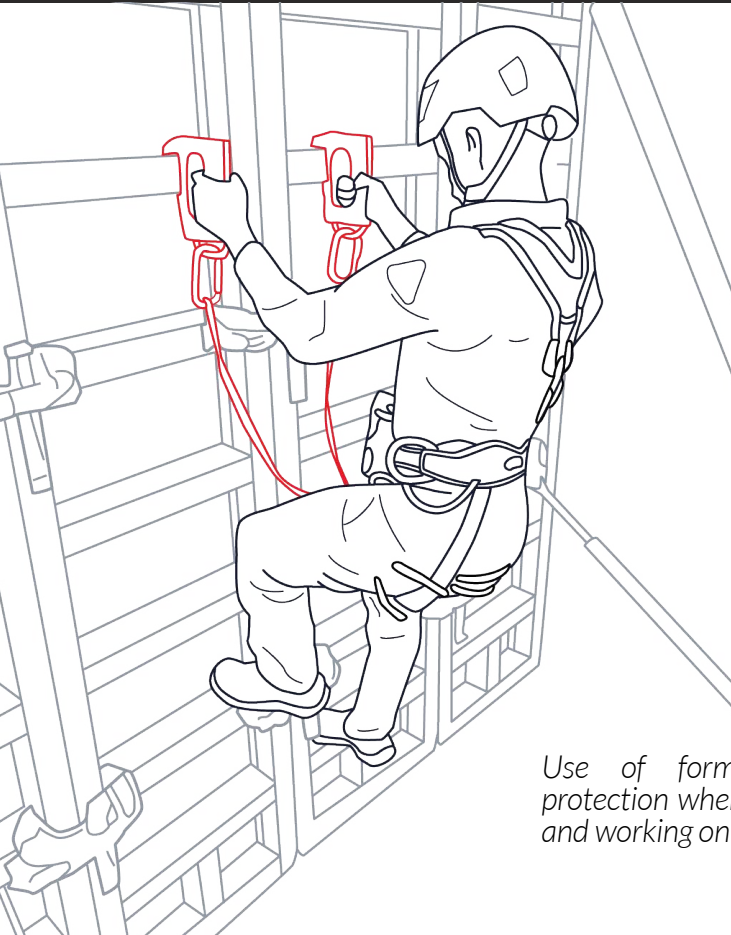

PATENTED

Use of formwork hooks provides protection when climbing, moving along and working on formwork walls.

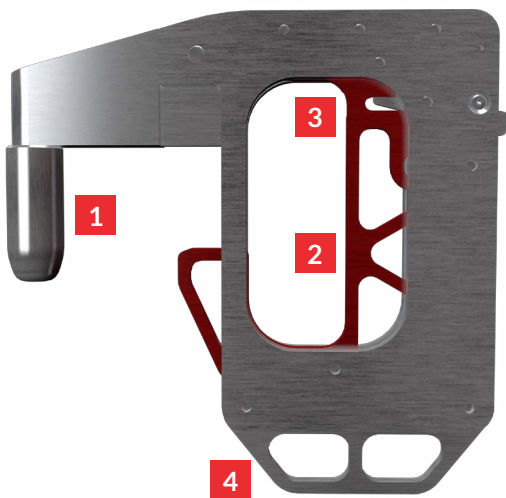

Ratchet in a hook construction is designed in a way that hook can only be detached after two separate and deliberate manual actions.

Lower section of hook has two attachment points for either fall arrest or work positioning. It also includes fall indicator which provides information whether device is still usable.

1 Pin

3 Slider ratchet

2 Slider

4 Lower section with fall indicator and attachment points

TECHNICAL INFO

STANDARD: EN795B:2012

MATERIAL: galvanized steel,
aluminium

WEIGHT:

FRAMAX 1,6 kg
MANTO 1,8 kg
TRIO 1,8 kg
ORMA 1,6 kg

PACKAGE DIMENSIONS:

FRAMAX 200x200x20mm
MANTO 200x200x20mm
TRIO 200x210x20mm
ORMA 200x200x20mm

CHARACTERISTICS

Formwork hook is a mobile anchor point conforming to EN795:2012B standard. It was designed to provide fall protection when working on formworks.

Formwork hook connects with formwork wales by pin which is meant to be inserted into slots in horizontal formwork wales.

Pin attachments were designed to fit to different formwork walls from different manufacturers.

Due to the low weight of the hooks they are convenient to work with. Tests performed during hook development (incl. tests with load cells) ensure safety of formwork structures when using hooks.

Interchangeable attachments for pin can be easily changed for other type to fit different type of formwork. Changing attachments require only two allen keys therefore it can be done on site when needed.

Formwork hooks can be used for moving and work positioning on formwork walls.

For work positioning (shown in a picture) lower hook is intended for positioning and upper for fall protection.

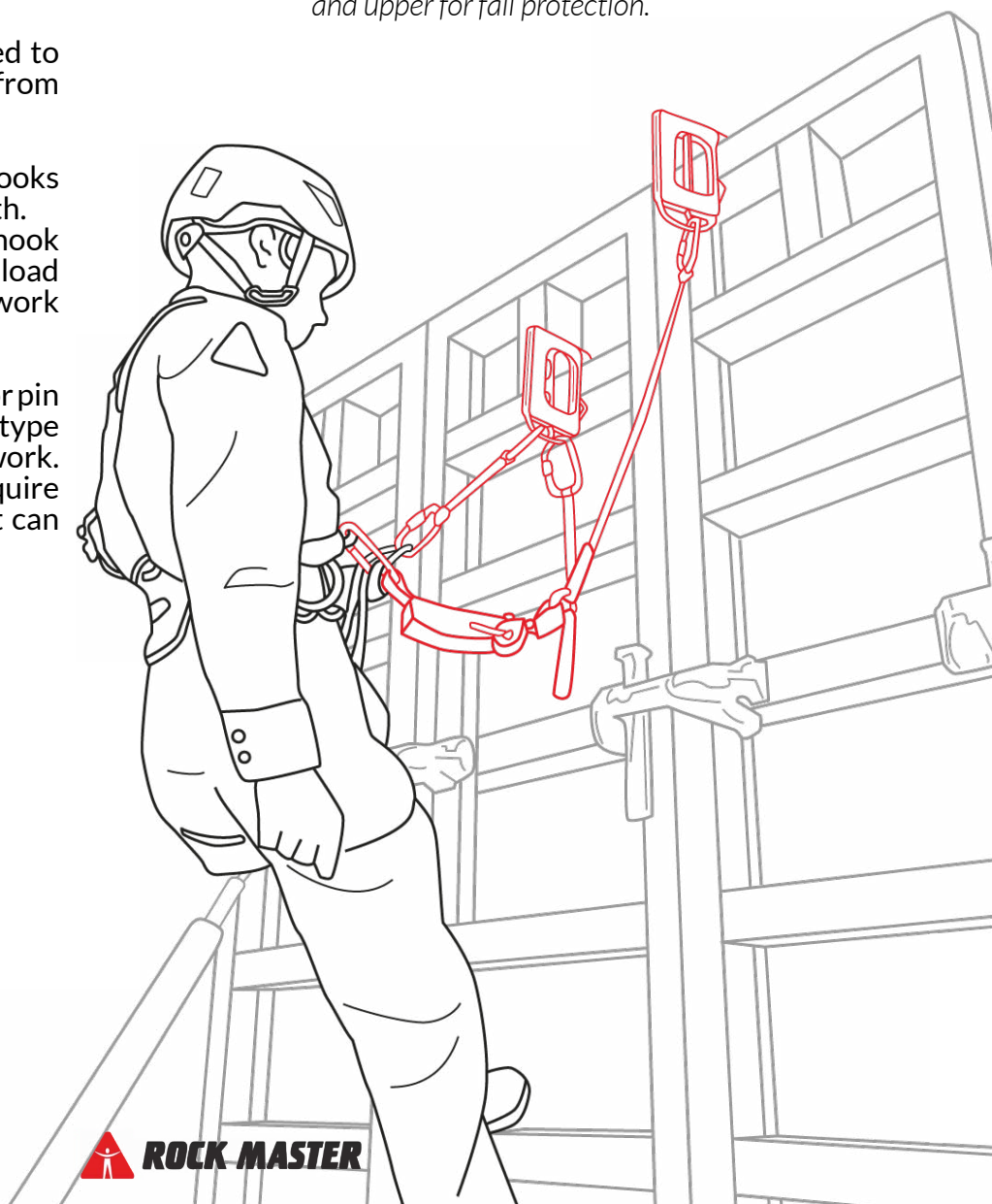

SAS FORMWORK SAFETY POST

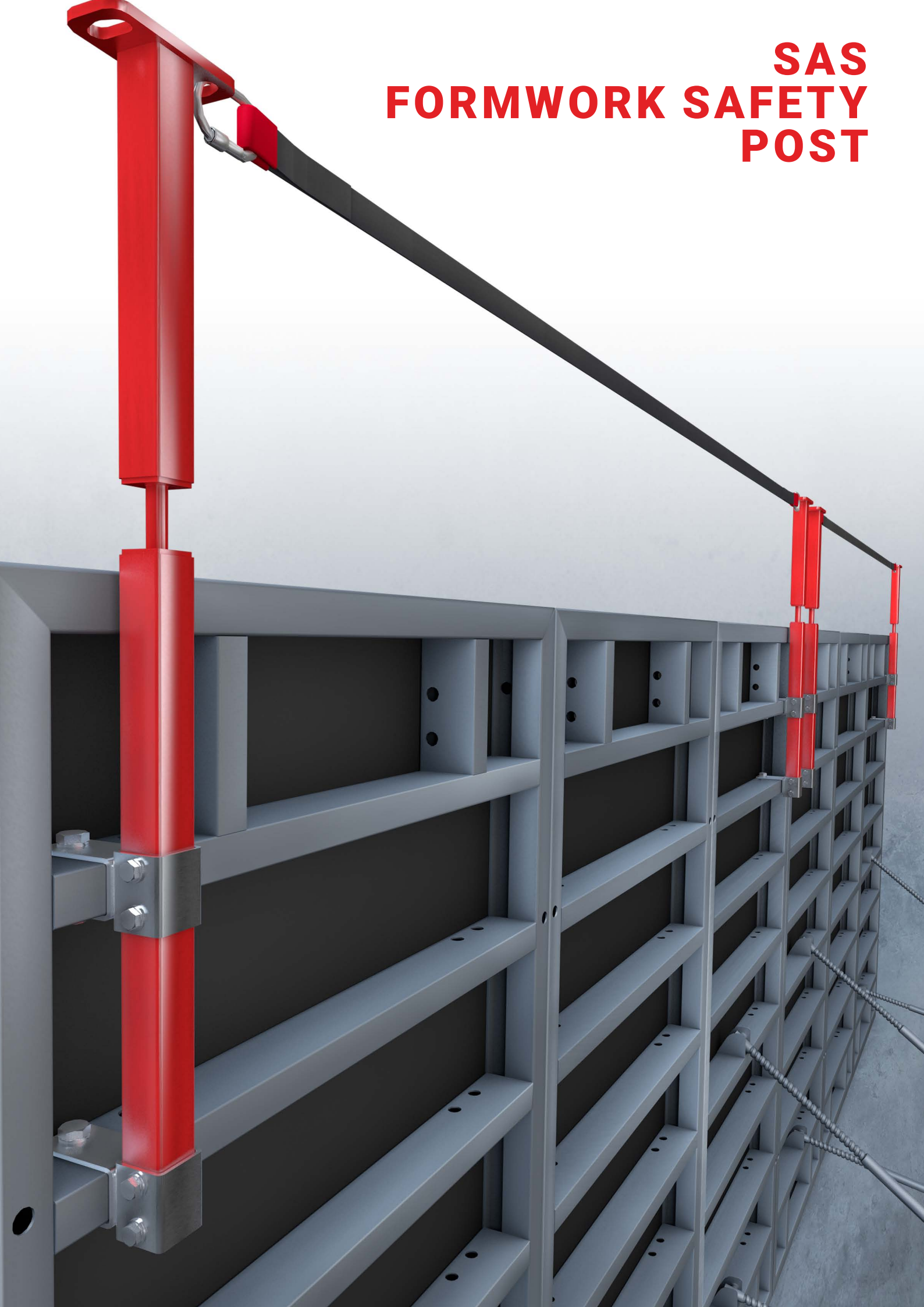

SAS - FORMWORK SAFETY POST

SAFETY POSTS DESIGNED TO WORK ON FORMWORK FROM MANUFACTURERS: DOKA, HÜNNEBECK, ULMA AND PERI

CHARACTERISTICS

Safety posts are intended to be mounted to horizontal wales of wall formworks by using purposefully designed brackets. Brackets were designed and tested for each supported formwork type (depending on manufacturer).

When installed, formwork post can be used as anchor point by itself (to use with e.g. SRLs), or as a post for different type of horizontal lifeline. It provides continuity of support during work or moving along formwork walls.

Neck in a body of safety post provides energy absorption when fall occurs. Deformation of these necks dissipate force to prevent formwork damage.

During development we performed tests on formworks with load cells to ensure that using safety posts won't cause any problems with formwork structure including deformations of any of their elements.

As a result of low weight of safety posts it is possible to mount them before forming a standing structure from formwork segments. It eliminates need of working at height just to install safety posts.



PATENTED

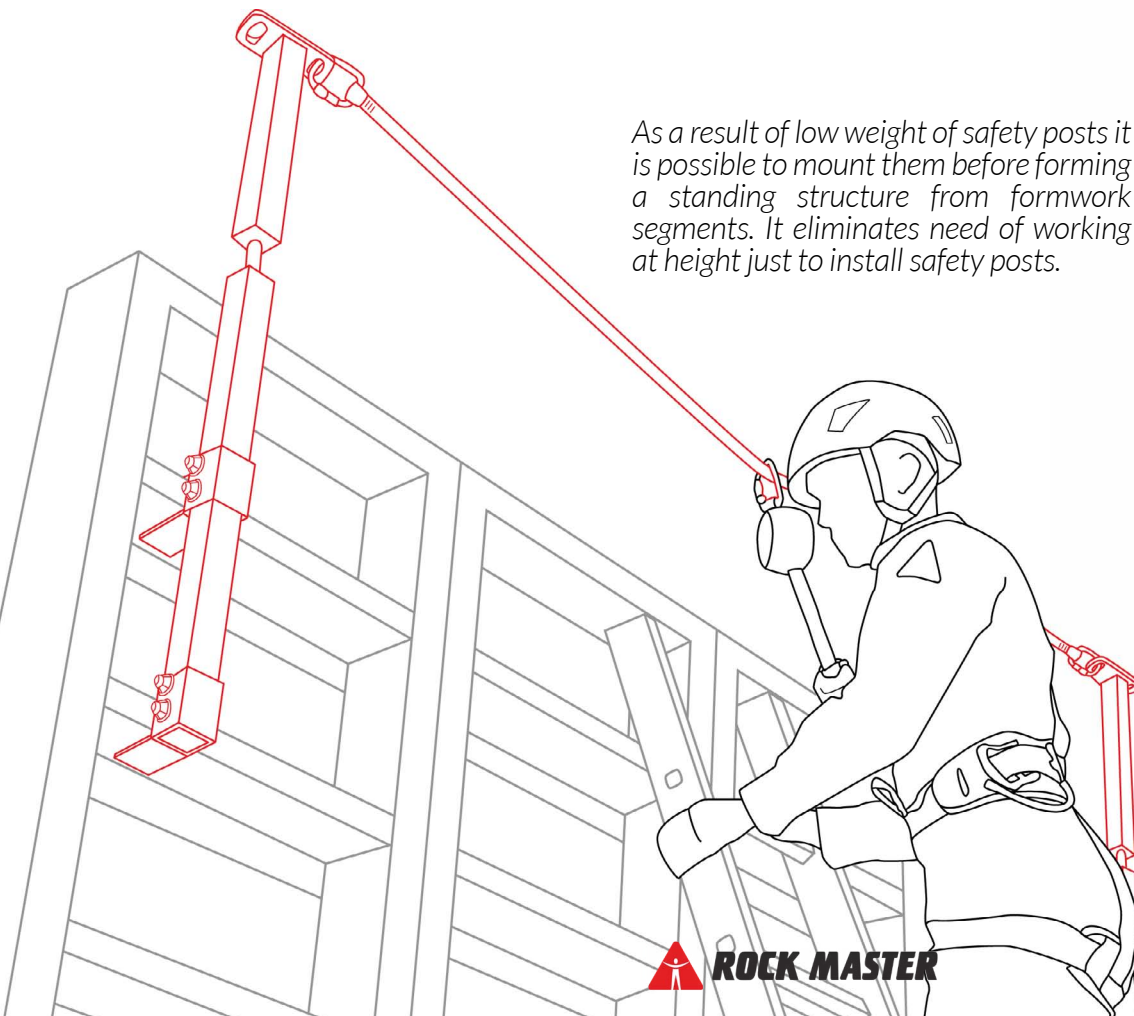

TECHNICAL INFO

STANDARD: PN-EN 795:2012 A

MATERIAL: galvanized steel

WEIGHT:

SAS D 11,6 kg
SAS H 9,1 kg
SAS P 8,3 kg
SAS U 8,1 kg

PACKAGE DIMENSIONS:

SAS D 1900x170x75 mm
SAS H 1300x150x90 mm
SAS P 1110x170x75 mm
SAS U 1110x170x75 mm

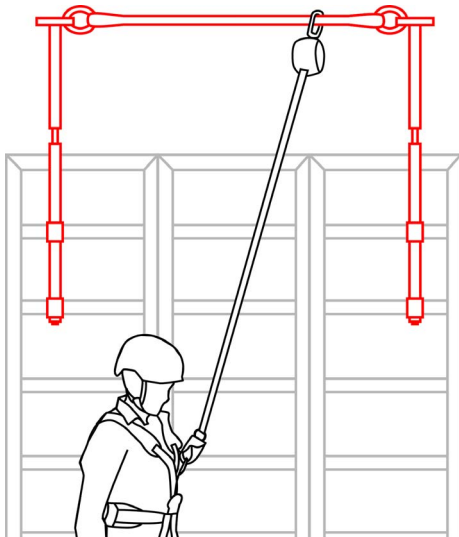

Self-retracting lifeline connected to horizontal flexible anchor line between two safety posts providing support during work on a movable ladder.

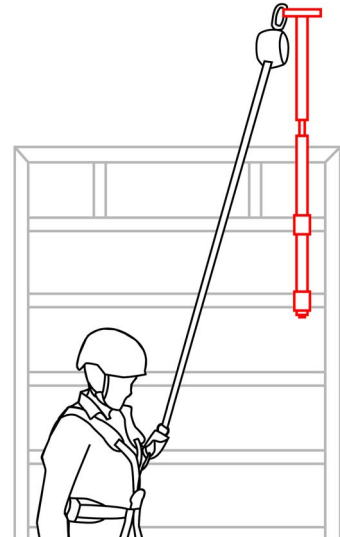

Formwork Safety Post can be used as anchor point for SRL or other type of fall protection devices and systems.



1 Plate for connecting with SRL/
horizontal lifeline e.g. Fine Line

2 Main body

3 Neck

4 Connector between
a post and formwork wale

5 Connector between a
post and formwork wale

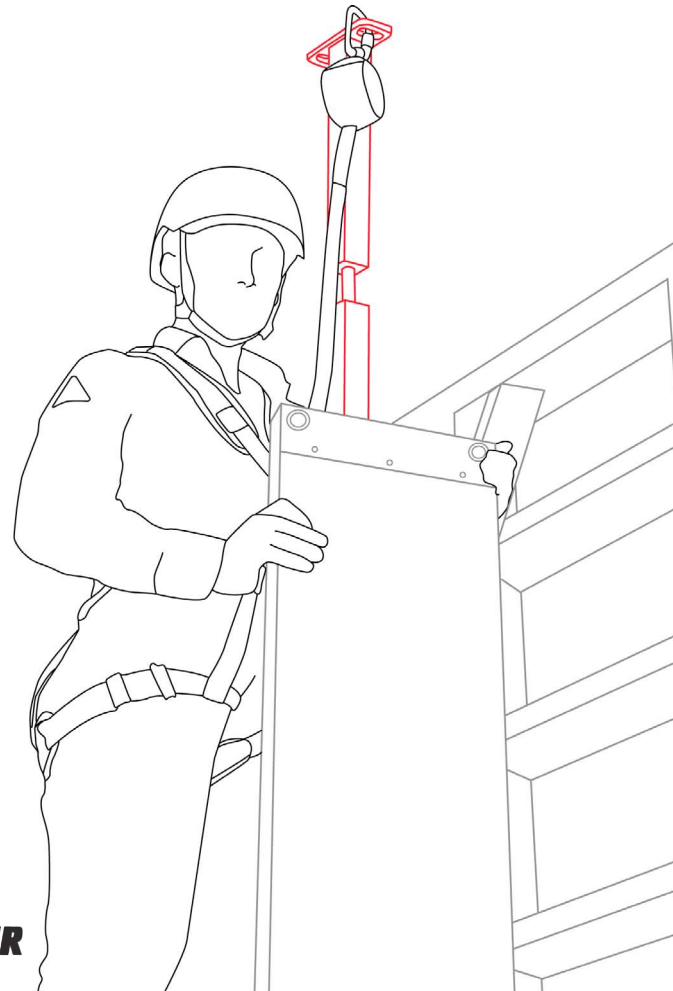

SCAFFOLDING SYSTEM T SAFETY NET



SCAFFOLDING SYSTEM T SAFETY NET

NON-INVASIVE SYSTEM T /STWR/ SAFETY NET FOR SCAFFOLDINGS. DRILL FREE INSTALLATION

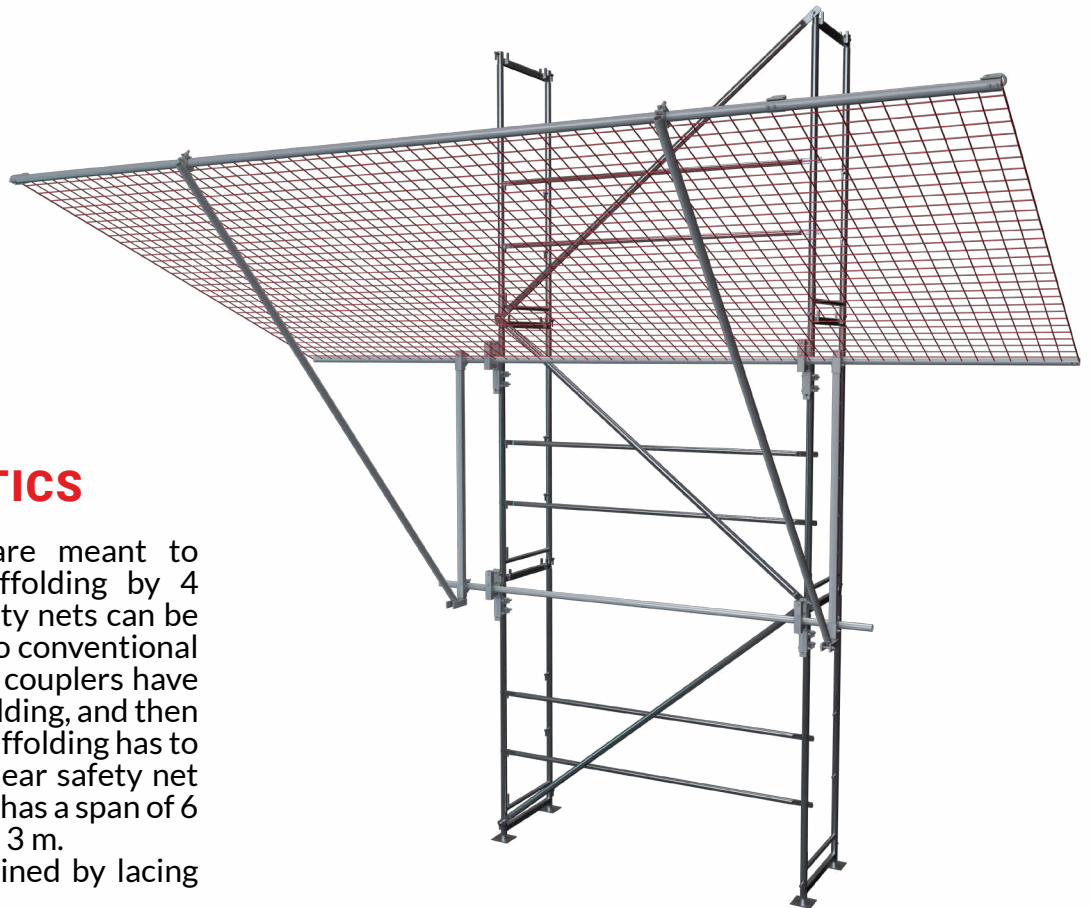

CHARACTERISTICS

System T segments are meant to be mounted to a scaffolding by 4 couplers. System T safety nets can be used as an alternative to conventional horizontal nets. At first couplers have to be installed on scaffolding, and then net can be attached. Scaffolding has to be anchored in nodes near safety net couplers. Each segment has a span of 6 m and catching width of 3 m. Segments can be combined by lacing or overlapping.

System T safety net protects workers in case of fall from height not exceeding 6 m.

It utilizes net with 10 cm mesh size. Net is combined with a layer of fine mesh to protect from falling dust, rocks or other particles.

Safety net will effectively protect fall of larger objects (such as beams) only when installed on a top floor.

Mounting for the first time requires use of crane, then to dismount (or add connecting segments) you will only need portable winch (Rock Master RWRM).

Net was tested by dropping 100 kg test mass from height of 7 m.

It is conforming and certified to EN1263-1 and EN1263-2 standards (certified by AGH University of Science and Technology).

TECHNICAL INFO

STANDARD:	EN 1263-1, EN 1263-2	MATERIAL:	galvanized steel, nylon, polypropylene	OTHER:	compatible with STWSi STWP
WEIGHT:	~10 kg	PACKAGE DIMENSIONS:	6 m		

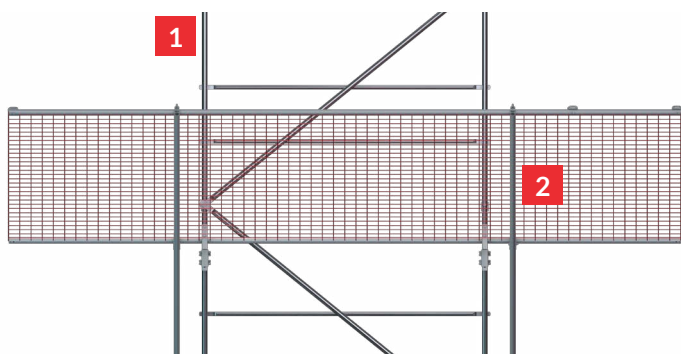

Frontal view

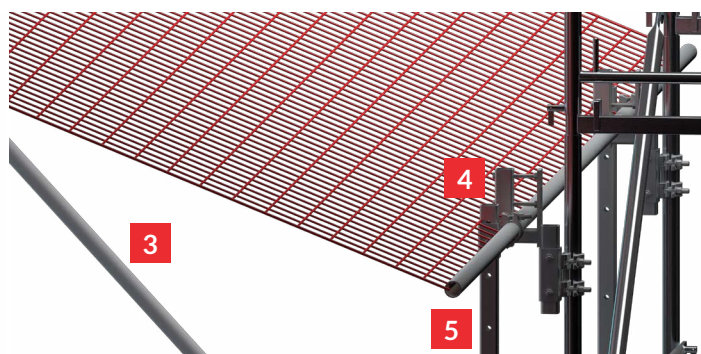

Side view

1 Scaffolding

3 Diagonal bracing tube

5 Vertical strut

2 Net 3,2m x 6m

4 Safety net coupler

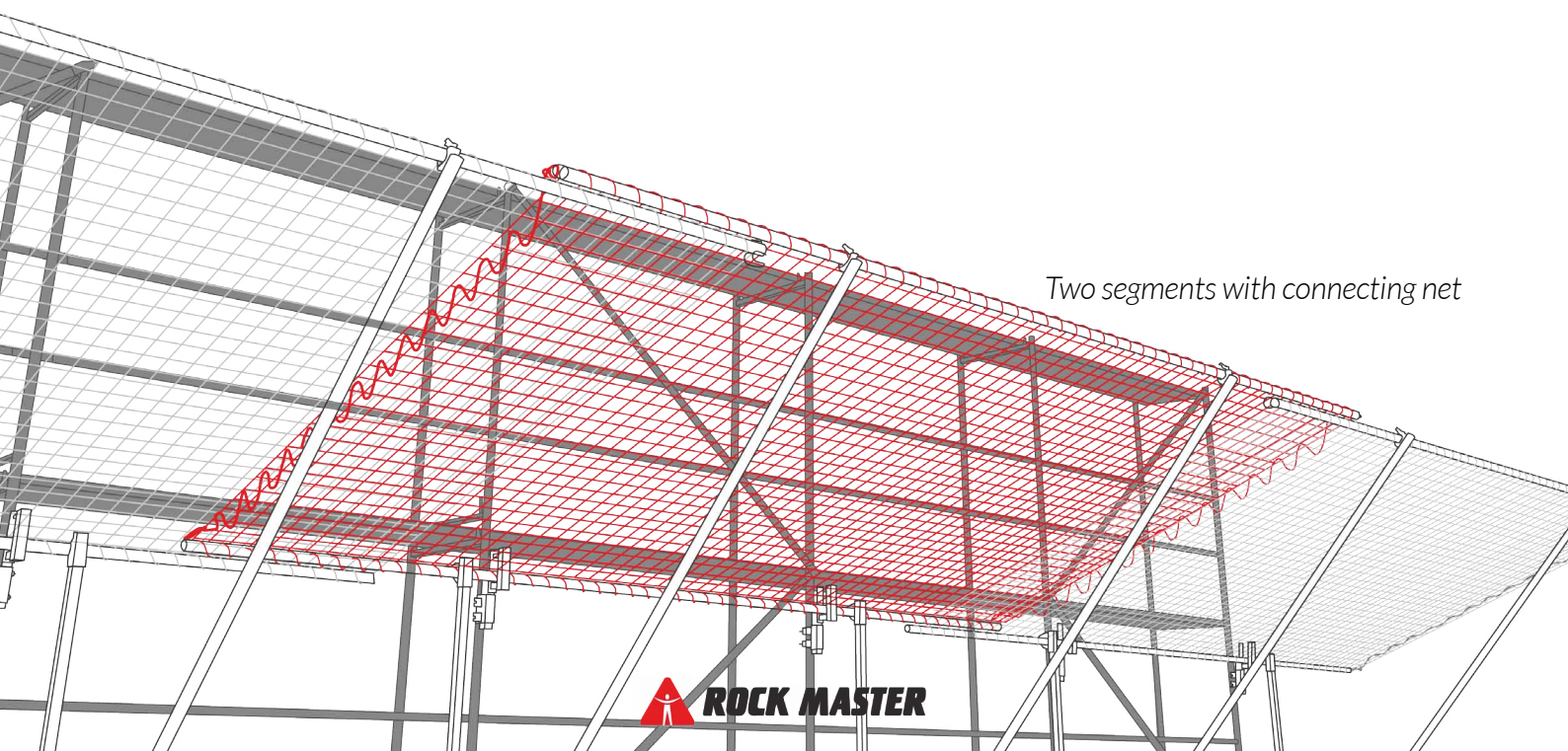

Two segments with connecting net

PILLAR TYPE T SAFETY NETS

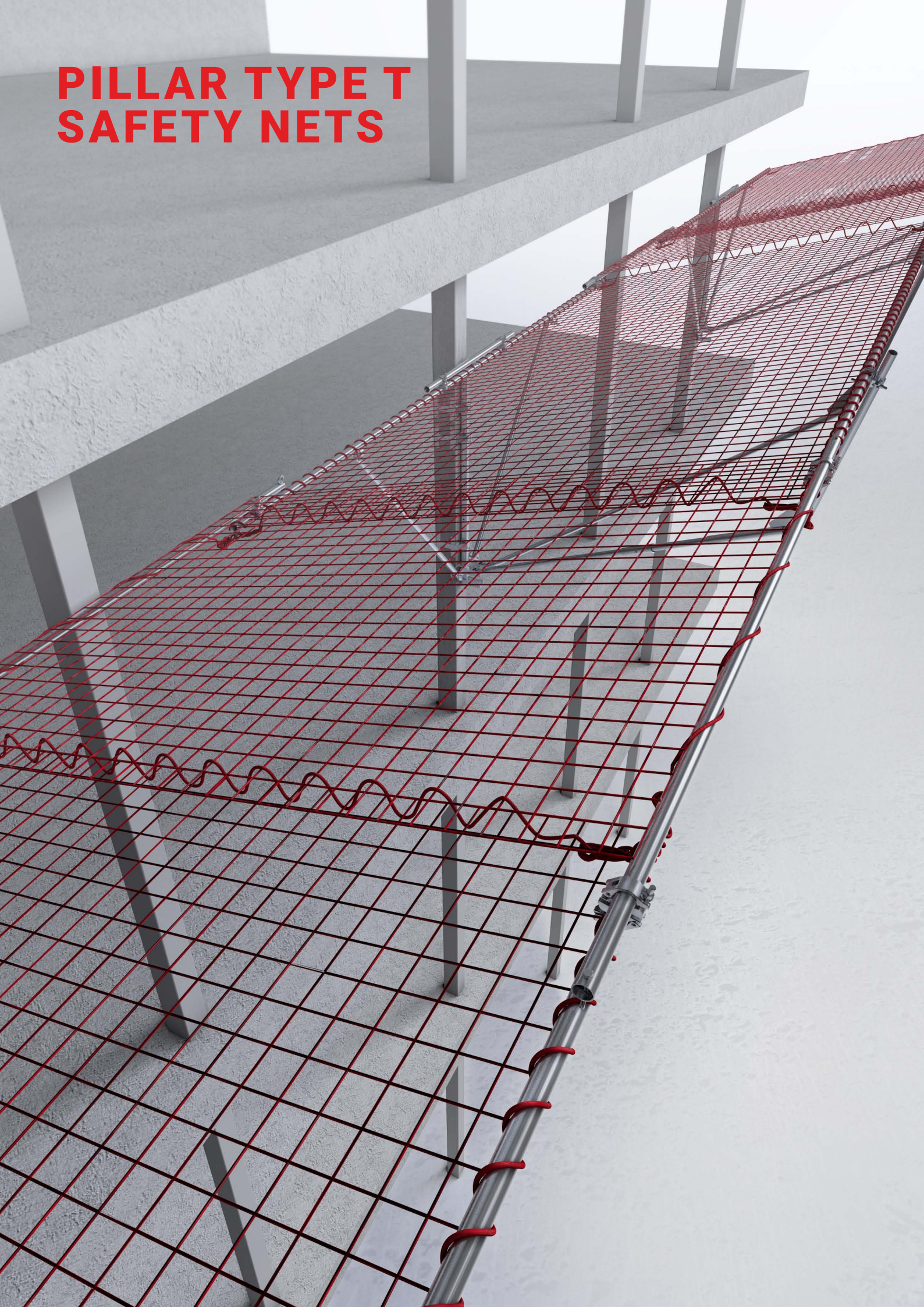

PILLAR TYPE T SAFETY NET /STWP/

NON-INVASIVE SYSTEM T /STWP/ SAFETY NET FOR PILLARS AND COLUMNS. DRILL FREE INSTALLATION



*Single system T segment
on a pillar*

CHARACTERISTICS

System T safety net segments are meant to be mounted to pillars by 3 belts fastened around pillars or walls. System T safety net can be used as an alternative to System S net. Mounting does not require any tools or drilling. It utilizes ratchet to tight belts around pillars.

Maximum span between pillars is 8 m (when using connecting segment). Each segment has span of 6 m, and catching width of 3 m. Segments can be connected by 2 m wide connecting segments.

System T safety net protects workers when falling from height not exciding 6 m.

It utilizes two nets with 10 and 6 cm mesh. It can be also installed with a layer of fine mesh to protect from falling dust, rocks or other particles.

Therefore it can stop both small and bigger objects incl. tools etc.

Safety net will effectively protect fall of larger objects (such as beams) only when installed on a top floor.

Mounting for the first time requires crane use, then to dismount (or add connecting segments) you will only need portable winch (Rock Master RWRM).

Net was tested by dropping 100 kg test mass from height of 7 m. It is conforming and certified to EN1263-1 and EN1263-2 standards (certified by AGH University of Science and Technology).

TECHNICAL INFO

STANDARD:	EN 1263-1 EN 1263-2	MATERIAL:	galvanized steel, nylon, polypropylene	OTHER:	compatible with STWSiSTWR
WEIGHT:	~160 kg	PACKAGE DIMENSIONS:	6m		

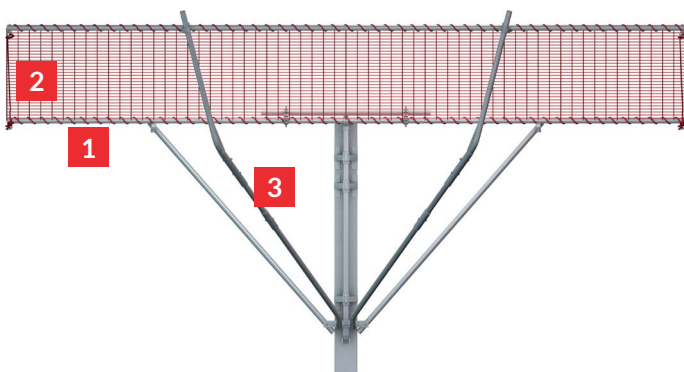

Frontal view

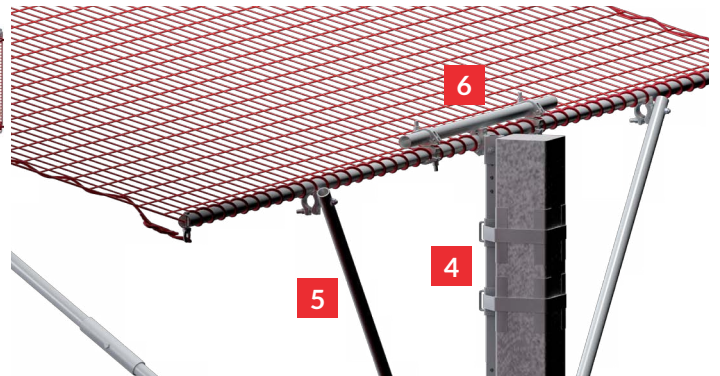

Side view

- | | | |
|--------------------------|---------------------------------|-------------------------|
| 1 Horizontal tube | 3 Diagonal bracing tubes | 5 Vertical strut |
| 2 Net 3,2m x 6m | 4 Fastening belts | 6 Bracing tube |

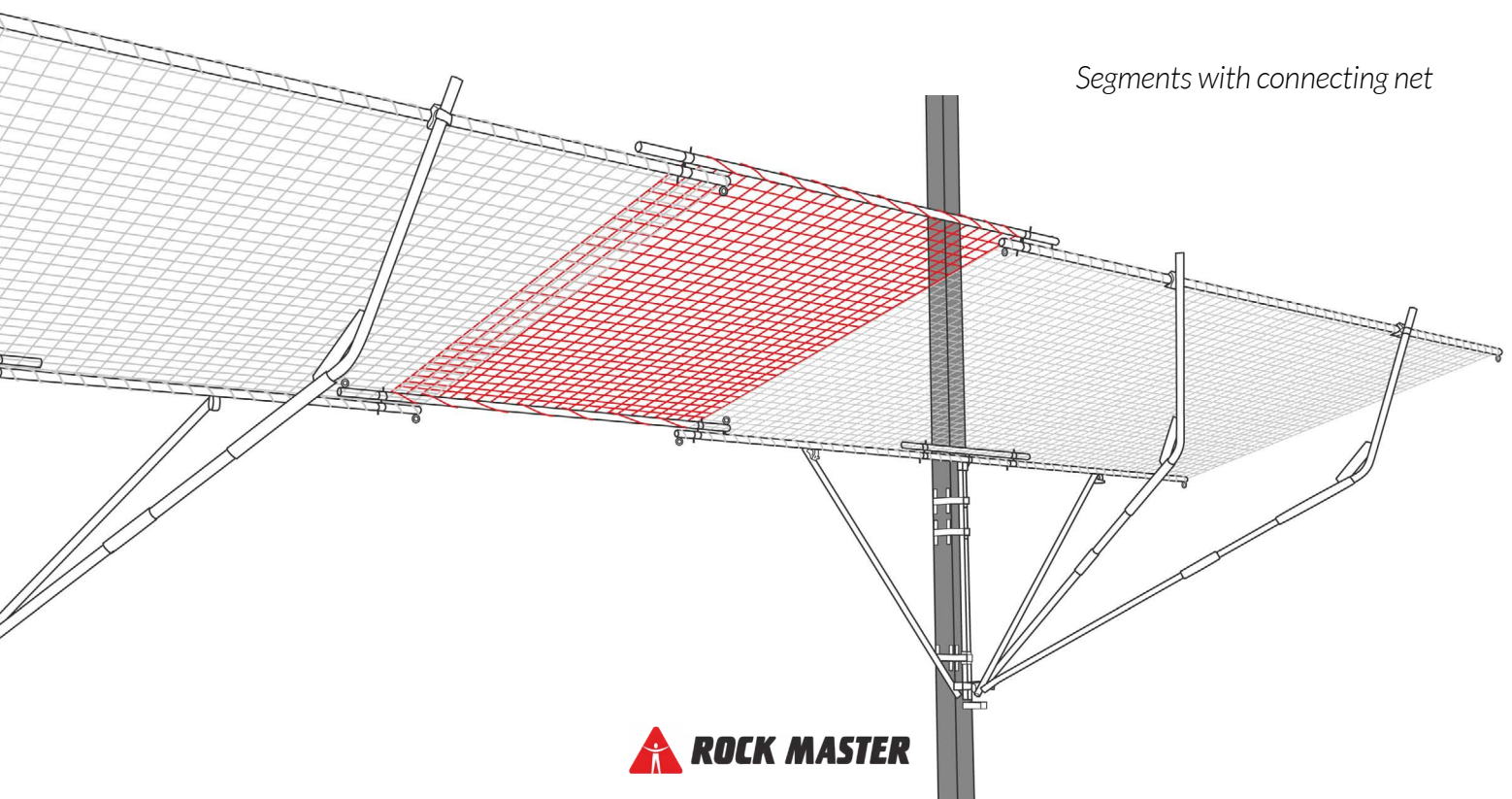

Segments with connecting net

**FLOOR TYPE T
SAFETY NET**

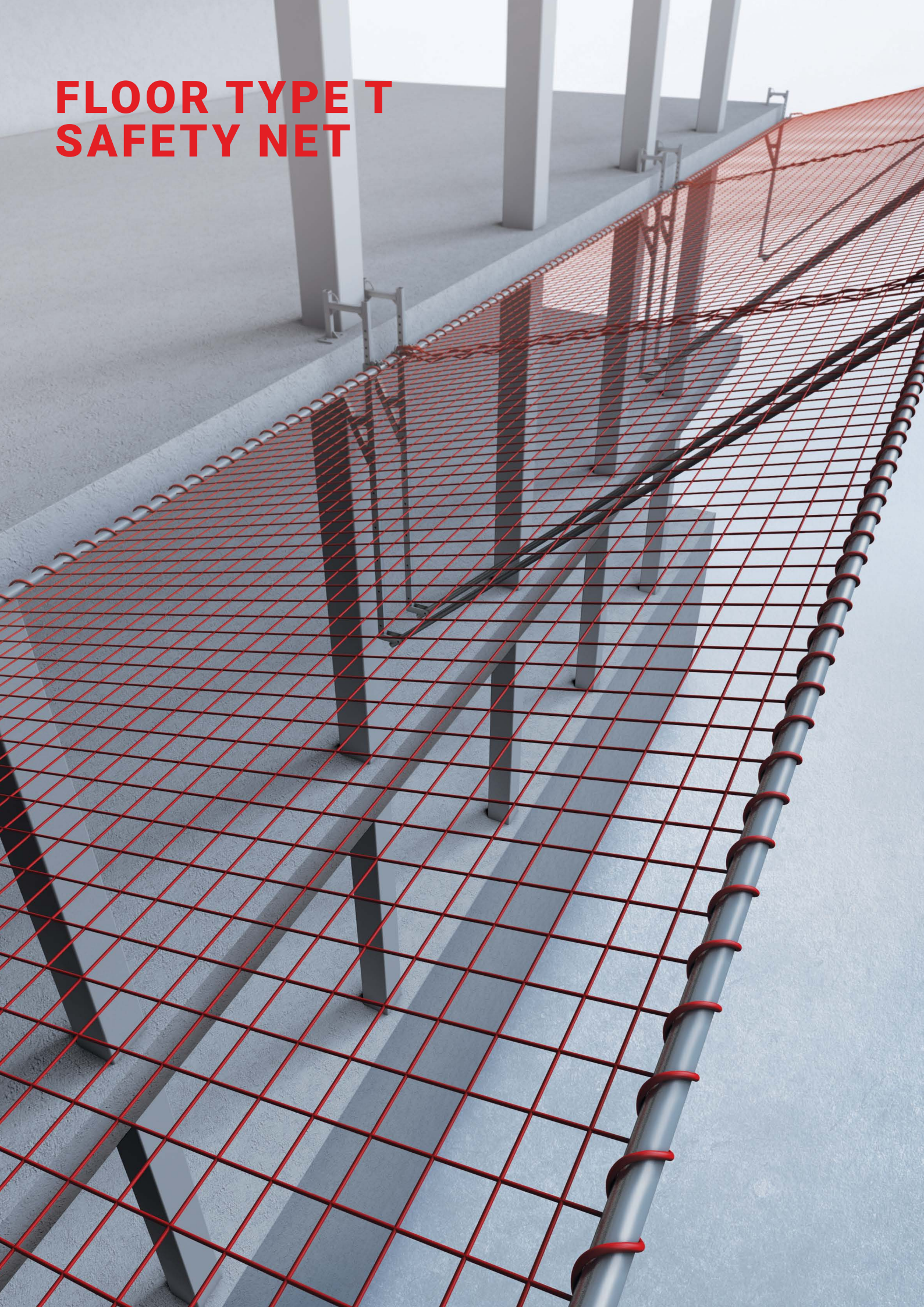

FLOOR TYPE T SAFETY NET

FLOOR TYPE SYSTEM T SAFETY NET / STWS/ SAFETY NET FOR WORKERS AND FALLING OBJECTS



CHARACTERISTICS

System T segments are meant to be mounted to the concrete floor by 4 anchors. Segments has a span of 6 m and catching width of 3 m. Segments can be combined by overlapping or lacing.

System T safety net protects workers in case of fall from height not exciding 6 m. It utilizes net with 10 cm mesh size layered with fine mesh to protect from falling dust, rocks and other particles.

It can be also combined with 6 cm mesh to protect against fall of smaller objects (tools etc.)

Safety net will effectively protect fall of larger objects (such as beams) only when installed on a top floor.

Mounting for the first time requires crane use, then to dismount (or add connecting segments) you will only need portable winch (Rock Master RWRM).

Net was tested by dropping 100 kg test mass from height of 7 m. It is conforming and certified to EN1263-1 and EN1263-2 standards (certified by AGH University of Science and Technology).

TECHNICAL INFO

STANDARD: EN 1263-1
EN 1263-2

MATERIAL: galvanized steel,
nylon, polypropylene

OTHER:

compatible with
STWP i STWR

WEIGHT: ~140 kg

**PACKAGE
DIMENSIONS:** 6m

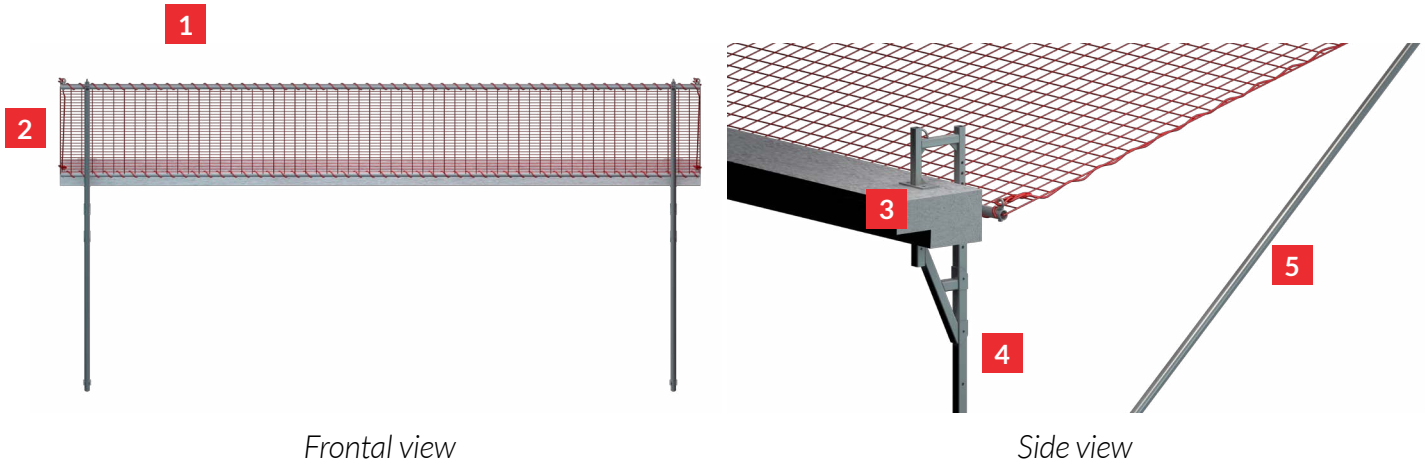

1 Longitudal tube

3 Clamp

5 Diagonal bracing tube

2 Net 3,2m x 6m

4 Vertical strut

System T Safety Net mounted to the floor

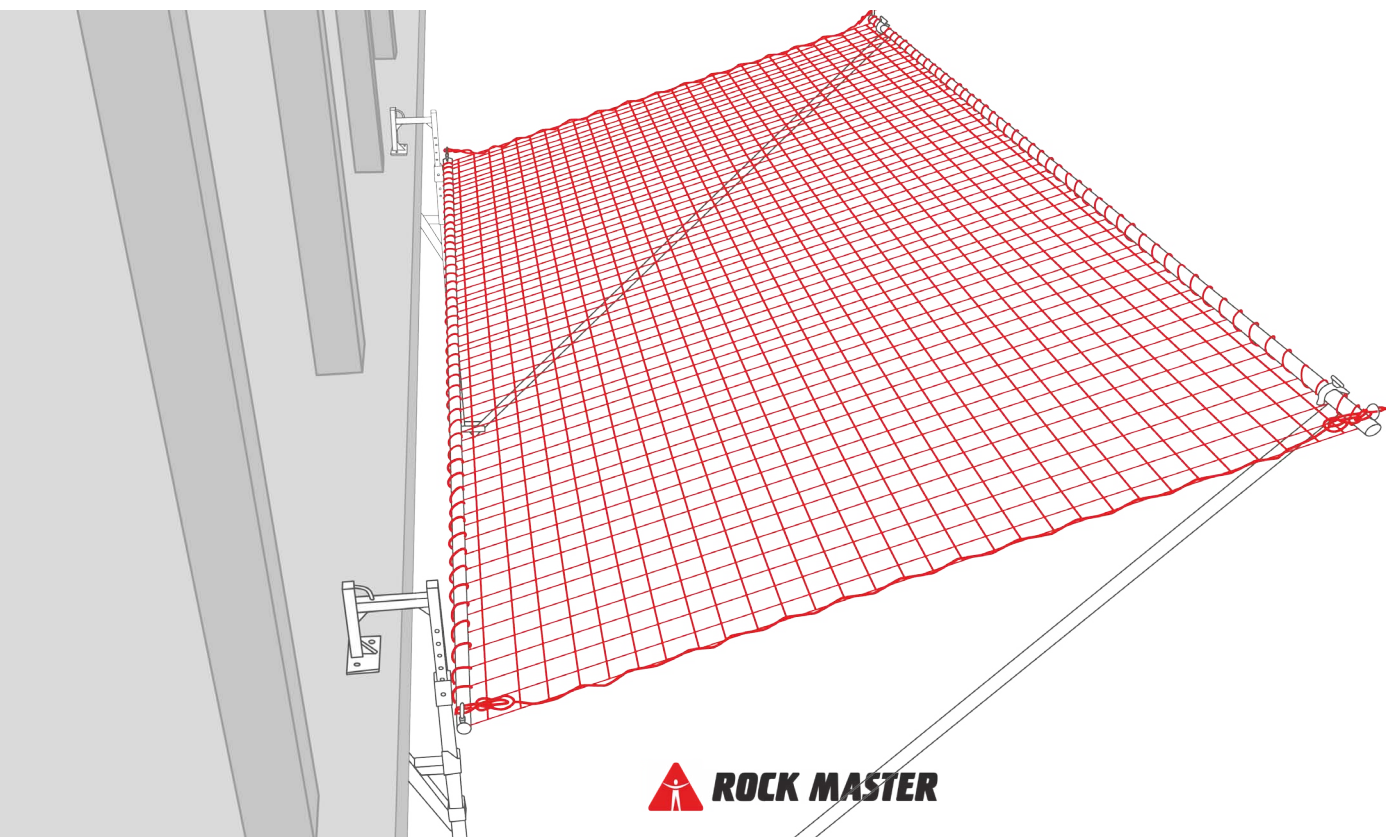



BUILD MASTER PRO FALL ARREST HARNESS

BUILD MASTER PRO

A LIGHT, TWO-PART FALL ARREST HARNESS, EASY TO COMBINE WITH A HIGH-VIS VEST

KEY FEATURES

The Build Master harness complies to the standard PN-EN 361:2005.

The harness is composed of a chest and a seat part, which can be detached from one another for more comfortable donning. The two parts are attached with easy-to-operate fast buckles. The two parts being separate make it possible to don them independently from one another and thus easily combine the harness with protective or work clothing.

The harness is equipped with two attachment points: a textile sternal attachment point, and a metal D-Ring dorsal point.

On the left and right side of the seat harness there are two gear loops for putting away equipment that's not currently in use.

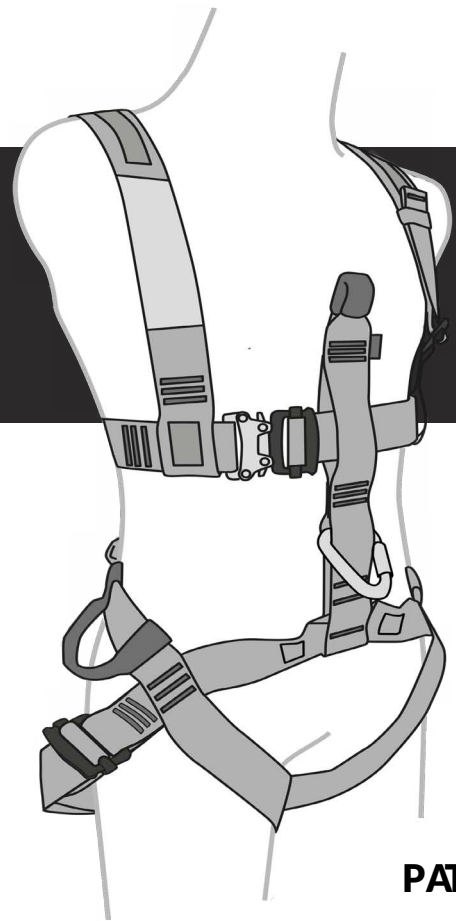

PATENTED

The light weight of the harness and the exceptional arrangement of its chest straps make it more comfortable for the user, even when worn for longer periods.

The Build Master harness is equipped with Velcro straps both at the bottom and at the top.

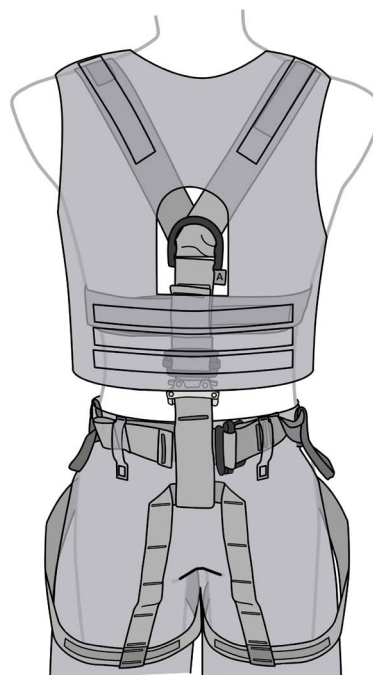
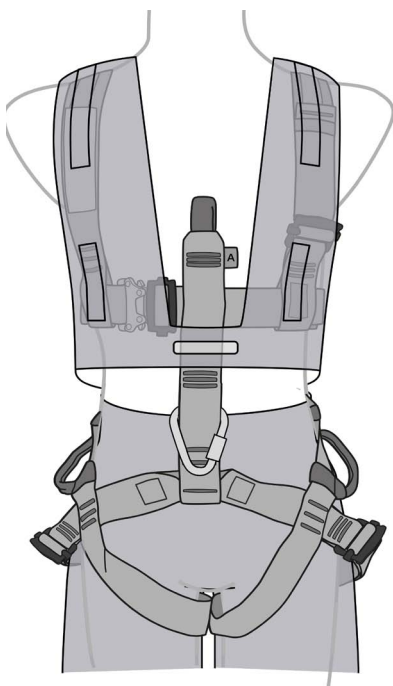

The Build Master harness is equipped with Velcro straps to combine the harness with a high-vis vest in a stable manner.

TECHNICAL FEATURES

STANDARD: EN 361, EN 1497

MATERIAL: polyester, nylon, steel, aluminum

WEIGHT:

S: 2,76 lb
M: 2,87 lb
ML: 2,98 lb
L: 2,98 lb
XL: 3,09 lb

SIZING:

S: 160-170 cm
M: 165-175 cm
ML: 170-180 cm
L: 1705-185 cm
XL: 180-195cm

- 1** sternal attachment point
- 2** dorsal attachment point
- 3** SPEED fastening buckles
- 4** gear loop
- 5** evacuation point
- 6** label

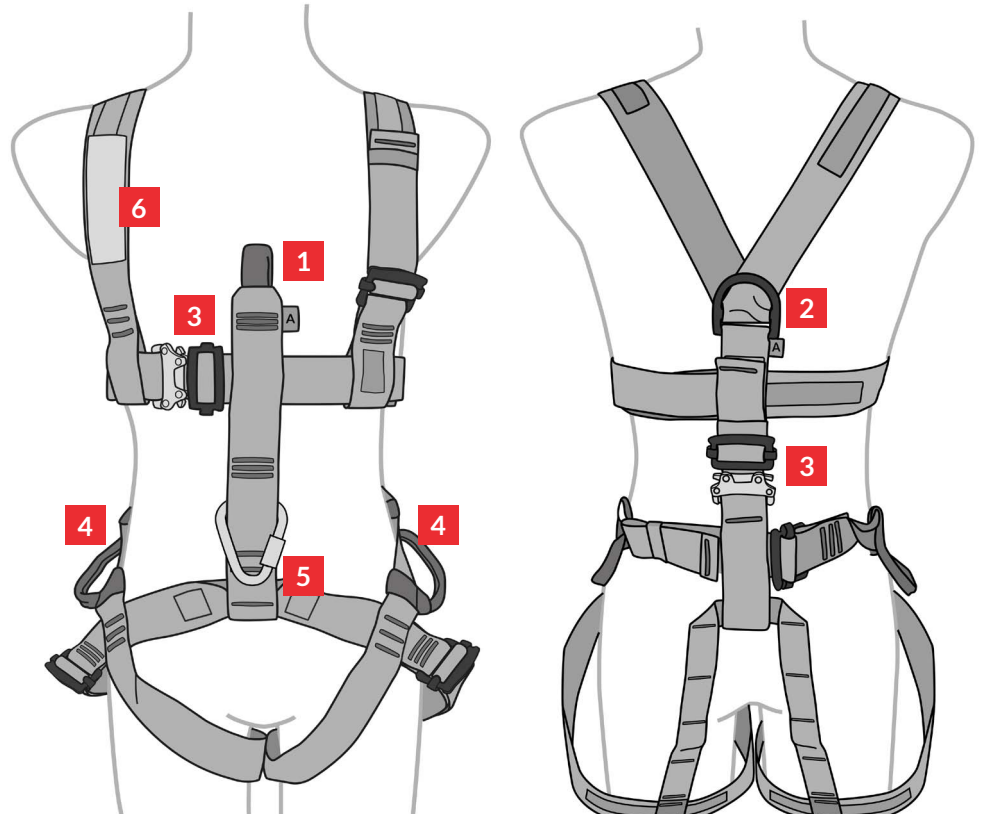

HOW TO DON THE HARNESS – OUR RECOMMENDATION

Detach the chest part of the harness from the seat part; start by donning the seat part, then don the chest part and connect them by threading the sternal strap through the front strap on the seat harness; then lock the buckles.

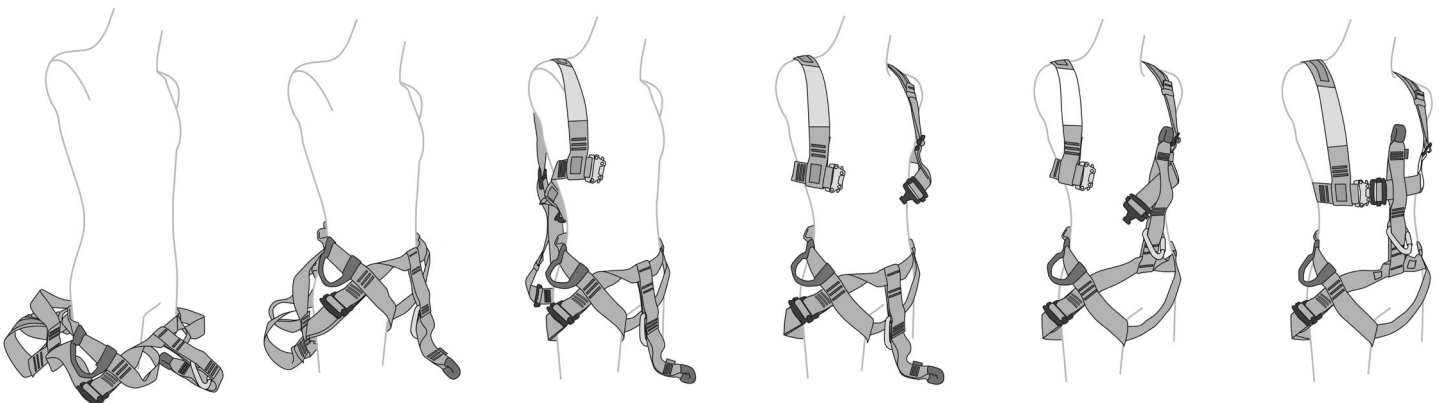



**UZO
DESCENT & RESCUE
DEVICE**

UZO

A DESCENT & RESCUE DEVICE - UZO 9

KEY FEATURES

The descent and rescue device, UZO 9, conforms to the standard EN 341:2011.

The device is operated manually and conforms to the requirements for the B class equipment.

UZO 9 is fitted with a fixed 11 mm static rope [1].

The device's core is a fixed metal plate placed between two halves of its housing. The device tapers towards the bottom, where the attachment point for an EN362 conforming connector is located [2].

Inside the device a system of rollers guides the rope and a rotating cam that changes position to lock and unlock the rope by pressing it against a fixed, unmoving contact part. The textile rope enters the device from above, runs downwards, circling the cam from the left-hand side, and then upwards between the cam and the contact. It exits the device housing towards the handle for descent control.

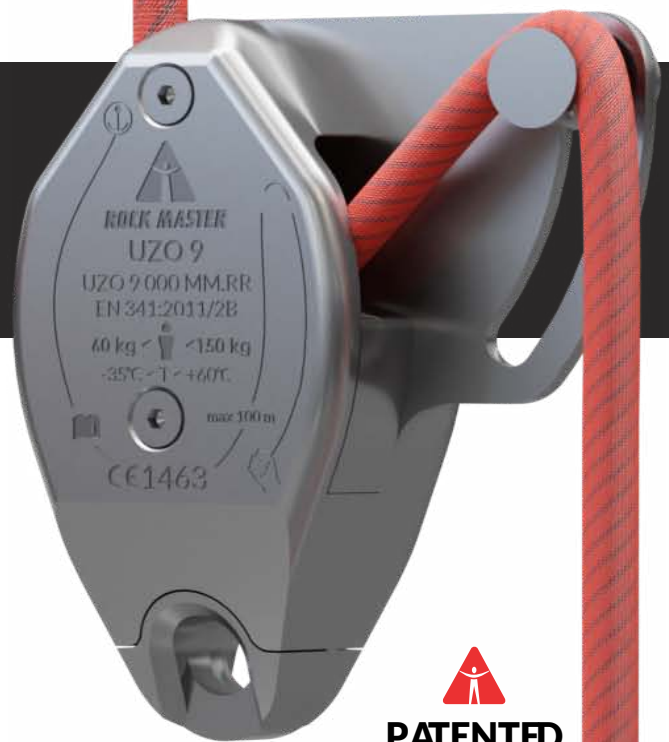

PATENTED

Other mechanical parts are situated on the other side of the metal plate, under the back of the housing – like a gear that coordinates the movement of the handle [3] with the rotating movement of the cam.

To replace the rope, it is necessary to unscrew and open the front part of the housing [4].



1 static rope, diam. 11 mm

2 connector EN362

3 handle for descent control

4 front of housing

TECHNICAL FEATURES

STANDARD:	EN 341:2011/2B	ACCEPTABLE TEMP.:	-35°C ÷ +60°C	RISK CATEGORY:	III
SAFE LOAD:	60 - 150 kg	ACCEPTABLE NO. OF USERS:	1 person	MAX DESCENT HEIGHT:	100 m

OPERATING MODES

Descent

Because of its technical properties and how they are potentially affected by the weight of rope below, the UZO device is only designed for short descents, where the weight of the rope below will not adversely affect the function of the device. The maximum free length of rope below the device is 15 m.

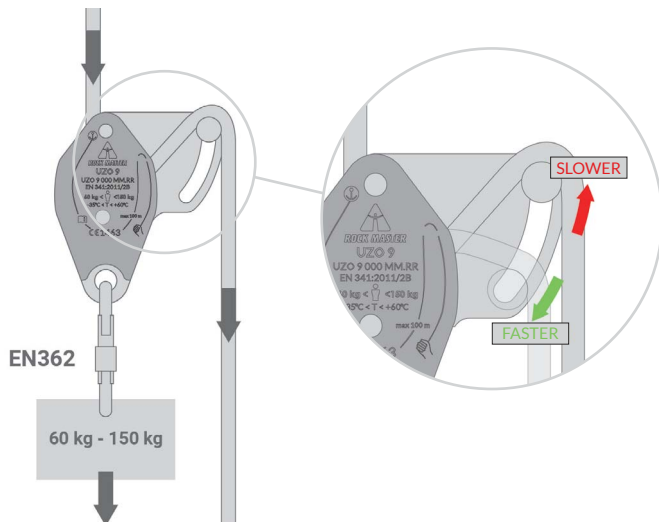

Descents of over 15 m are possible only if the rope entering the device is bagged and moves with the operator.

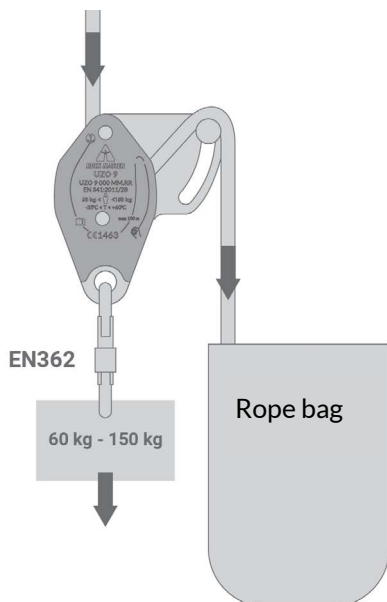

Lowering over the edge

Use additional protective measures: a second rope and a fall arresting device.

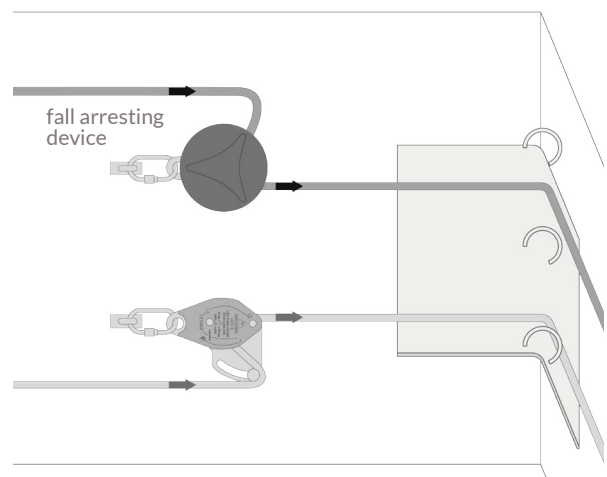

Lowering from structures

When using the UZO 9 for lowering, ie. upside down, the length of rope exiting the device does not affect the function. For this reason, lowering over the edge has no height limit, as long as the maximum single descent height of 100 m is not exceeded.

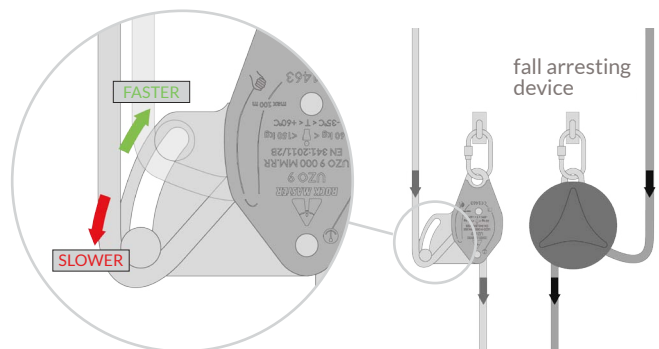



**HORIZONTAL
SAFETY SYSTEM**

PSA

HORIZONTAL SAFETY SYSTEM PSA 7



KEY FEATURES

PSA-7 is a complete horizontal safety system with a steel cable in one handy device. Inside the housing, there are 7 m of steel cable, extended and retracted using the handle.

The system can be anchored to various structural parts using anchors according to EN 795A with a minimum strength of 30kN. Recommended are dynamic anchoring posts of the DSA type.

One person is able to tension the cable unassisted. No other tools or tensioning devices are needed or allowed – all it takes is the handle located at one side of the housing. It is also not allowed to use any tools or objects to elongate the handle.

To loosen the tensioned cable, simply pull the locking lever towards the exit opening, from which the cable extends, to unlock the mechanism and retract the cable. Throughout this operation the handle needs to be able to move freely.

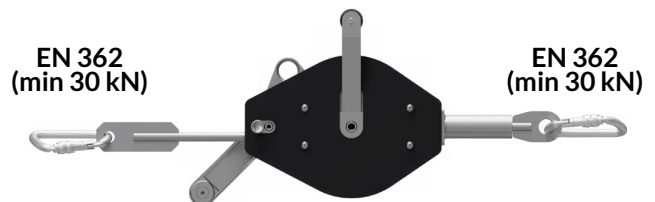

PARTS OF THE PSA 7

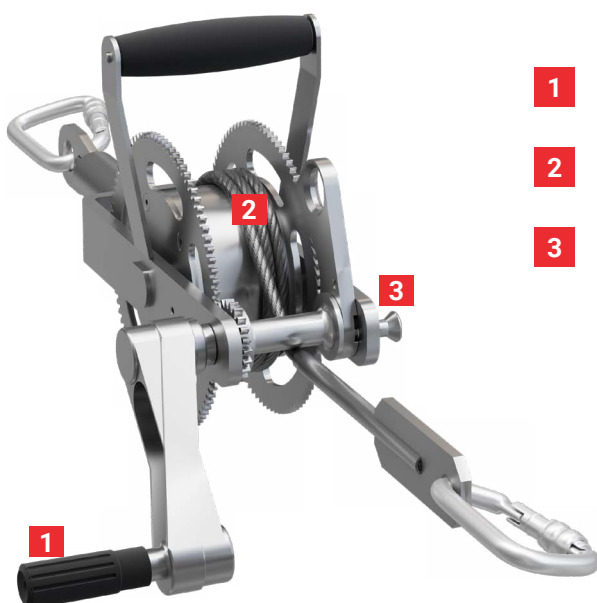

- 1** tensioning handle
- 2** rope groove
- 3** locking lever



TECHNICAL FEATURES

STANDARD:	EN 795 typ B	MATERIAL:	Stainless steel, galvanised steel
MAX. NO. OF USERS ALLOWED:	2 people	WEIGHT:	9,85 kg

USING THE SYSTEM

The maximum allowed span of cable with no intermediate modules is the length of the cable (7 m in the longest version).

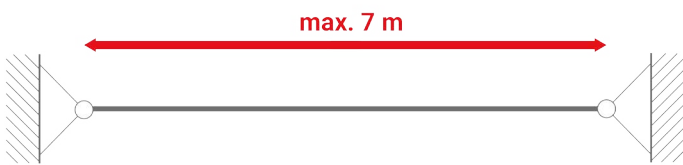

If intermediate modules are used, the minimum distance between those should be 2 m.

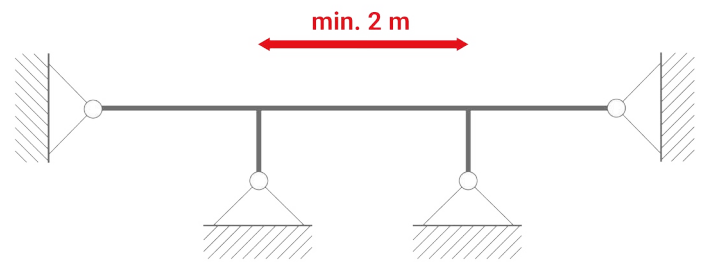

The minimum angle of change of direction using an intermediate module is required is 135°

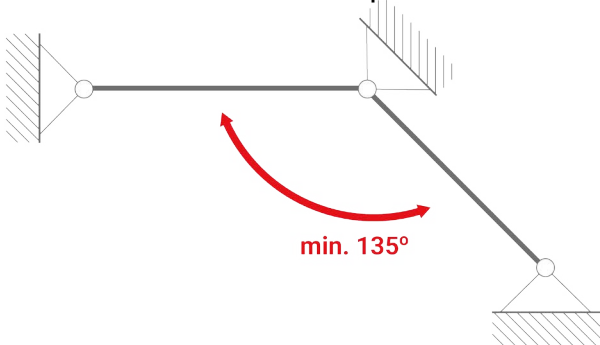

The maximum deviation from the horizontal must not exceed 15°

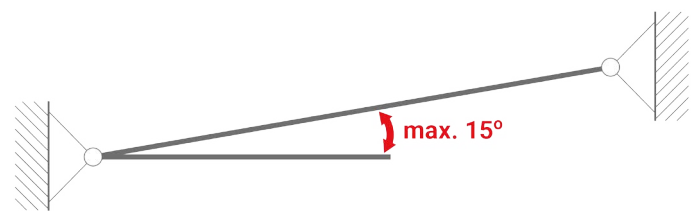

The minimum free fall clearance (MSD) is calculated as follows:

1. System deflection (B – the maximum deflection when used by an adult. For the 7 m length version B equals 1,8 m);
2. The length of other functional parts: lanyard according to EN 354, an energy absorber according to EN 355, a fall arrest slider according to EN 353-2, a fall arrest block according to EN 360 (C – please refer to the manuals for the actual system parts);
3. Safety factor – 2,75 m (D)

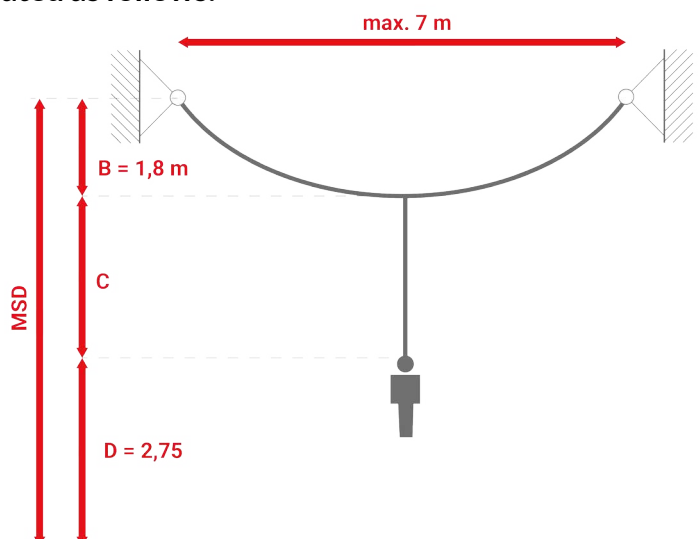

Two people can use the system at once. While using the system in this manner, all operators should be aware of the risk that their coworker will be pulled towards them in the case of their fall. There is also a swing fall potential.

QUADROD ANCHOR POST FOR WOODEN CEILING FORMWORK



QUADPOD

ANCHOR POST FOR WOODEN CEILING FORMWORK

KEY FEATURES

The SQ10 anchor post is designed to be mounted to horizontal formwork boards (wooden) of wooden ceiling formworks. SQ10 meets the requirements of PN-EN 795:2012 type A for the simultaneous use by 2 persons. The unique design of the post also provides an energy absorbing function to protect the worker and to help avoid damage to the formwork structure.

The post can be used standalone (also anti-pendulum) or as a component in horizontal rope lifeline systems.

The attachment point for connectors is located at a height of 70 cm from the ground, which increases work comfort, both if used as standalone or within a safety system.



The anchor post is mounted on the horizontal plywood formwork board using 24 screws. The formwork board must be nailed to all the formwork beams.

Both the post and the base plate are made of corrosion protected and/or stainless material.

The set contains the following:

- an energy absorbing anchor post including an attachment point for connectors
- a set of screws

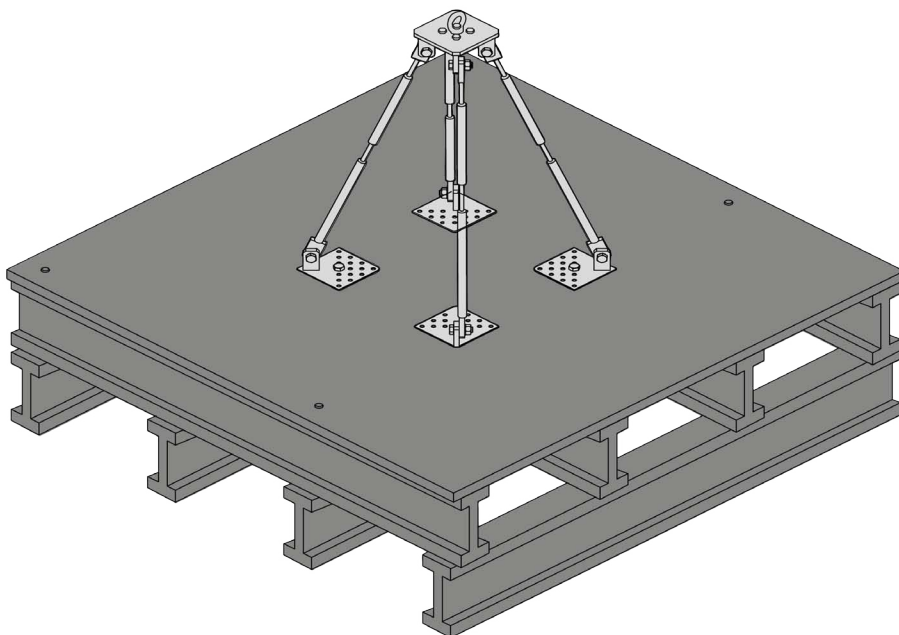

Anchor post mounted to the ceiling formwork.

TECHNICAL FEATURES

STANDARD:	EN 795:2012 – A	BASEPLATE DIMENSIONS:	44 cm x 44 cm	MATERIAL:	galvanised steel stainless steel
MAX. WEIGHT OF USERS ALLOWED:	max. 100 kg/person	MAX. NO. OF USERS ALLOWED:	2 people	WEIGHT:	6,9 kg

INSTALLATION:

The person (user) carrying out the installation must be equipped with the appropriate personal fall protection equipment: a harness, a helmet and the proper energy absorbing/fall arrest lanyard attached to an anchor point of at least 12 kN strength.

The post is designed to be mounted to a horizontal ceiling formwork panel made of plywood.

Two types of screws are used for the installation of each post.

- 20 washer head screws WPO – 4,2 x 40

- 4 pan head wood screws 6x60 mm

- Attach the feet of the post in the designated spots as shown in the picture. Use four washer head screws and one pan head wood screw for each foot; the wood screw must pass through the girder located under the board.

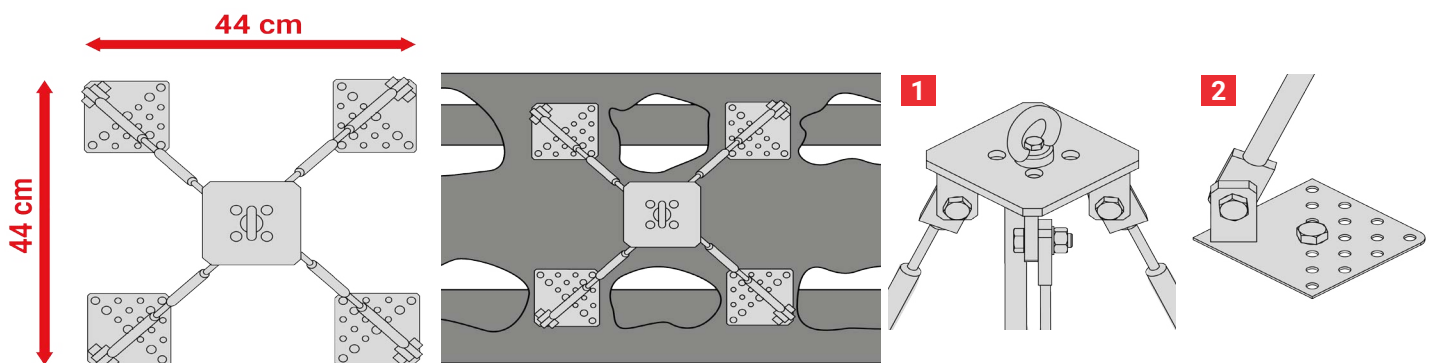

Anchor posts can be used to set up temporary horizontal lifelines. Acceptable are all horizontal systems according to EN 795B.

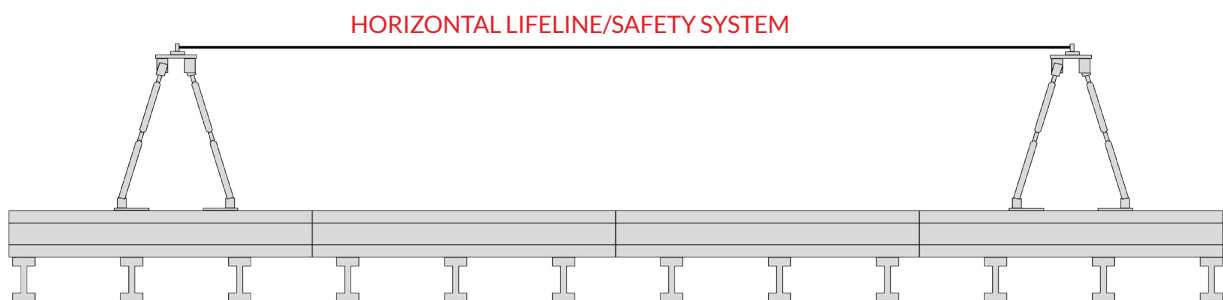



ROCK MASTER

CBR Rock Master Sp. z o. o. Sp. k.
Królewska 94/11, 30-079 Kraków,
+48 12 290 30 35;
office@rockmaster.eu
NIP: PL 945 18 44 489

Research and Development Center
Sportowa 20, 32-083 Balice,
cbr@rockmaster.eu
www.rockmaster.eu