

USER MANUAL



ANCHOR HOOK CLAMP FOR SCAFFOLDING TOWERS – HAWP

Risk category 3
For one user only

Maximum load allowed: 100 kg

Read the manual carefully before use!

MANUFACTURER'S DETAILS



Manufacturer's logo

HAWP_L
HAWP_S

Manufacturer's trade name

1 person
Max 100 kg

Maximum load allowed

HAWP_L 000/MM/RRRR
HAWP_S 000/MM/RRRR

Serial number Month and year of
manufacture

CE 1463

Number of the notified body
responsible for quality control of the
manufacturing process

EN 795:2012 class B

Number of the EU standard applicable
to the device

THIS SIDE UP

Indication of the correct position of the
device



An indication to read the user manual
before using the device

THE DESCRIPTION AND DESIGN OF THE

DEVICE

HAWP hook clamps (large – HAWP_L and small – HAWP_S) developed by CBR Rock Master are B type anchor devices designed for use on scaffolding towers.

The device complies with EN 795B:2012, which means that it is a temporary anchor point installed in a way that prevents accidental disconnection from the structural element to which it is mounted. However, it is possible to disconnect them intentionally from the structure without the use of additional tools.

HAWP hook clamps (large – HAWP_L and small – HAWP_S) are equipped with holes to attach connectors conforming to EN362.

They provide the user with a continuous belay during work or traversing the scaffolding tower structures.

Anchor hook clamps are to be attached to vertical parts of the scaffolding towers. To do this, unlock the gate, spread the jaw of the hook clamp, put it around the vertical profile of the scaffolding tower, close and lock. The inner surfaces of the HAWP_L hook clamps have a particular shape that makes them universal for large diameter scaffolding tower supports – they work well with both the round and the square-like ones. The inner surfaces of the HAWP_S hook clamps are arched and fit a small diameter support (48,3 mm).

HAWP hook clamps have a two-latch locking mechanism, which prevents their accidental release during operation. The first part of this mechanism is a latching hook, which keeps the locking lever (the second part responsible for keeping the locking mechanism closed) in place.

The HAWP hook clamps are attached to the ends of a double shock absorbing lanyard, using connectors conforming to EN362.

The HAWP hook clamps are very lightweight; thanks to this they are comfortable to use and do not cause stress during work while providing both continuous belay when moving between structures

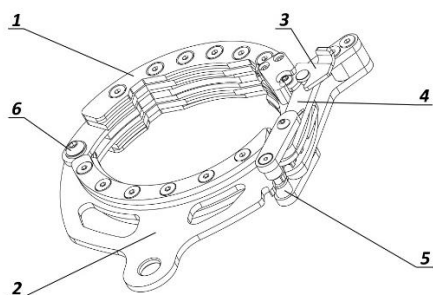

Fig. 1: large anchor hook clamp for scaffolding towers – HAWP_L

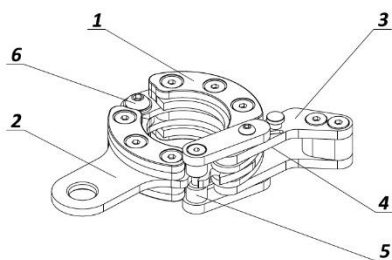

Fig. 2: small anchor hook clamp for scaffolding towers – HAWP_S

Key parts of the device:

1. Fixed jaw
2. Moving jaw with anchor point and pinion
3. Latching hook
4. Locking lever
5. Locking pin
6. Jaw hinge

Address:
Krolewska 94/11
30 – 079 Krakow



Contact us on:
office@rockmaster.eu
+48 12 290 30 35

GENERAL RULES FOR USING PROTECTIVE EQUIPMENT FOR SAFE WORK AT HEIGHT

Introduction

- Fall protection equipment should only be used by persons in good health and shape, with no contraindications to performing work at height and who have been adequately trained by a competent and authorized representative of the manufacturer.
- Fall protection equipment should only be used as indicated and designed. The incorrect use or incorrect combination of fall protection equipment can cause severe personal injury or death.
- It is strictly forbidden to modify the device or tamper with it. Any such action shall void the warranty.
- All repairs must be undertaken only by the manufacturer or by persons authorized by said manufacturer.
- Before commencing work using fall protection equipment it is essential that a rescue procedure, and, first and foremost, an adequate set of rescue equipment are in place.
- Work using fall protection equipment is to be carried out only under the guidance of a competent supervisor.

Using the device

- Before commencing work, the user has to:
 - read the user manual carefully
 - learn (and train) all basic rescue procedures and techniques
 - check the condition of the device (all parts working correctly, no damage, no wear and tear, no corrosion/rust, no abrasions) and the correct assembly of all parts of the system as well as whether all parts fulfill the requirements of corresponding standards. The technical condition of all parts of the protection system is to be checked upon completing work as well
 - check, whether parts of the system do not interfere with one another
- It is forbidden to use the equipment if any of the parts does not work correctly.
- The only allowed PPE for fall arrest are harnesses according to EN 361.
- It is only allowed to attach the fall absorbing lanyard to the harness at the connection point marked with the capital A.
- While working with fall protection equipment, proper anchor points according to EN 795 have to be used; there has to be sufficient space below the worker, exceeding the length of fully deployed fall absorber.
- The fall protection system should be fitted and fastened in a way that reduces the risk of falls and/or their potential length to a minimum. There has to be sufficient space below the worker. Also the distance required for fall absorption (the length of the deployed fall absorber) and the fall distance have to be considered.
- Exercise caution while working in difficult or demanding conditions: avoid extreme temperatures and weather as well as caustic substances.
- After a fall has been arrested, the device is to be retired! A device that has been retired is to be destroyed!, i.e. rendered non-usable.
- If there are any doubts about the technical condition of a piece of equipment, it should be retired. Such a device can be reused only after a full inspection has been carried out by the manufacturer and a written approval has been issued.

Inspection and maintenance

- The device functioning correctly is crucial to preserving the user's health and safety; therefore, regular inspections are necessary.
- An inspection is to be carried out at least once per year (at least every 12 months). An inspection can be carried out by a competent authorized person; for more complex devices, an inspection is to be carried out by the manufacturer or a person authorized by the same in writing. Check the technical condition of the device as well as the function and all the markings, which need to be clearly visible. If the result of the inspection is unsatisfactory, the device should be retired.
- All information in regard to the equipment, including the periodic inspection results, shall be recorded in its designated logbook by the persons responsible for storing and maintenance. It is forbidden to use any equipment if its corresponding logbook has not been maintained properly and/or does not contain crucial information, if documents are missing or incomplete or if the equipment's history is unclear/unknown.
- The equipment's lifespan depends on environmental conditions, any harmful factors present, the intensity of use, and storage conditions.
- The lifetime of metal parts is not limited, as long as regular periodic inspections are carried out and recorded by competent persons.
- A device is to be retired if the maximum lifetime given by the manufacturer has been exceeded. The manufacturer can retroactively change the lifetime of a specific type of product and publish this information eg. on their website.
- To clean the device, wash it with clear, lukewarm water (up to 30°C), using a soft wipe; for more persistent dirt, use natural soap. Leave the device to dry in room temperature.
- The device can be sanitized using spray disinfectants.
- Only silicon-based spray grease can be applied to metal devices, if needed. Any excessive grease on the surface touching the rope or on the outside can be removed using a clean wipe.

Storing and transporting

- To ensure the longevity of equipment, when not in use, store it in its original packaging in a dry, ventilated place, at room temperature.
- Make sure to avoid exposure to dust and salty environments, high temperatures, harmful and corrosive substances, abrasive and sharp surfaces and edges when storing and transporting the equipment.
- Do not leave the equipment out where it is directly exposed to sunlight.

HAWP_L - DETAILED INSTRUCTIONS FOR USE

Before use, familiarize yourself with the below information on the correct handling of the device for use on scaffolding towers; the information complements the general instructions for use of fall protection equipment and/or builds on them.

The anchor device for scaffolding towers can be used in combination with other parts and devices to create a full fall protection system.

Scope of use:

Conforming to:

The anchor device conforms to EN 795B:2012

Load limit: one person

Maximum weight of user depends on the fall absorbing lanyard used.

Allowed temperature range: -30°C ÷ +50°C

NOTE:

Each piece of equipment should be accompanied by a set of instructions for its use, maintenance and periodic inspections and repairs in the language of the future user's country.

Lifetime and inspections

Standard wear and tear is to be expected when the device is used as designed and not exposed to any harmful environmental factors. The lifetime of the device is not limited as per manufacturer's instructions, as long as regular recorded inspections by competent persons are performed.

The device should be inspected before and after every use by the user.

That notwithstanding, the device has to be inspected at least once every 12 months. The inspection is to be carried out by the manufacturer or a person authorized by the same in writing and is to follow the checklist provided by the manufacturer.

If a fall has been arrested, the anchoring device is to be retired immediately.

Before commencing work on scaffolding towers connect the HAWP hook clamps using screw lock connectors to each end of a double fall arrest lanyard. This setup will provide belay while moving along the scaffolding tower to reach the work site.

Scope of use:

The large hook clamp for scaffolding towers (HAWP_L) is designed for use on scaffolding towers with large diameter supports, and thanks to its inner shape it works well with various support shapes - from round, like ULMA, ALUPROP, to square, like MULTIPROP by Peri.

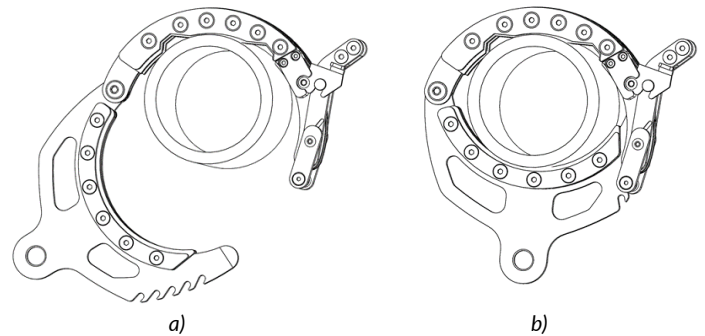

Fig. 4: HAWP on a rounded profile support: a) open; b) closed

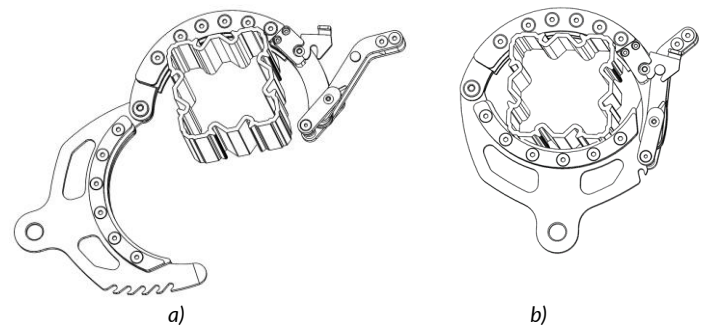

Fig. 5: HAWP on a square profile support: a) open; b) closed

Using the HAWP_L

Installing the HAWP_L on the vertical support of a scaffolding tower – begin by opening the hook clamp. To do it, grab the device with your left hand near the hinge and hold it, the anchoring eye facing you, and then use your right hand to unlock the locking lever by pulling the latching hook.

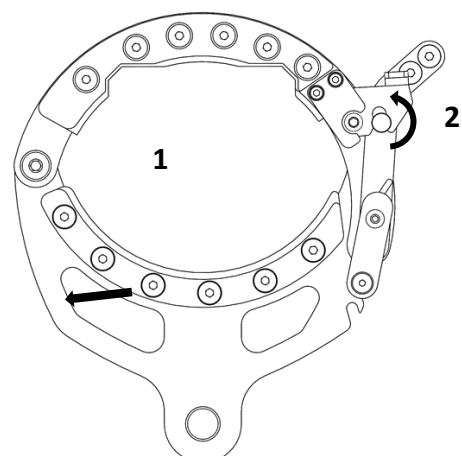

Fig. 6 Opening the HAWP_L

INSTALLATION AND USE

The person performing the installation work (user) must be equipped with the proper fall protection/fall arrest PPE before commencing any work: a harness, a helmet, a double shock absorbing lanyard (Y or V) with appropriate connectors.

For users weighing max. 100 kg (incl. equipment) – a double shock absorbing lanyard with screw-lock carabiners. Because of the distance between the scaffolding tower supports it is recommended to use a long fall absorbing lanyard, however remember that the total length of the setup (including hook clamps and connectors) must not exceed 2m!



Fig. 3: PPE recommended for work with HAWP_L or HAWP_S

Address:
Krolewska 94/11
30 - 079 Krakow



Contact us on:
office@rockmaster.eu
+48 12 290 30 35

Pull the locking lever towards you to unlock the locking pin in the pinion of the moving jaw.

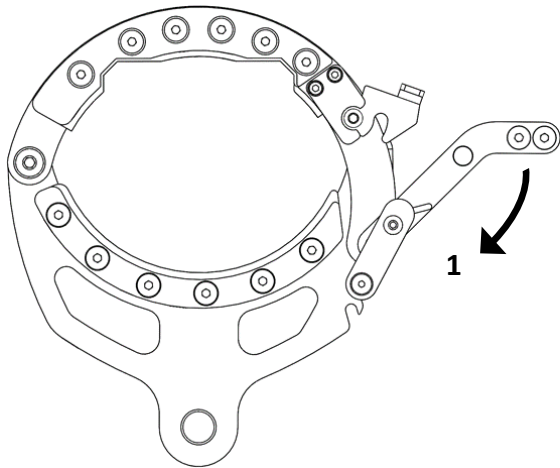

Fig. 7 Releasing the locking lever

While pulling the locking lever away (1), pull the shorter locking jaw using your right hand thumb (2) and pull out the locking pin out of the pinion (3).

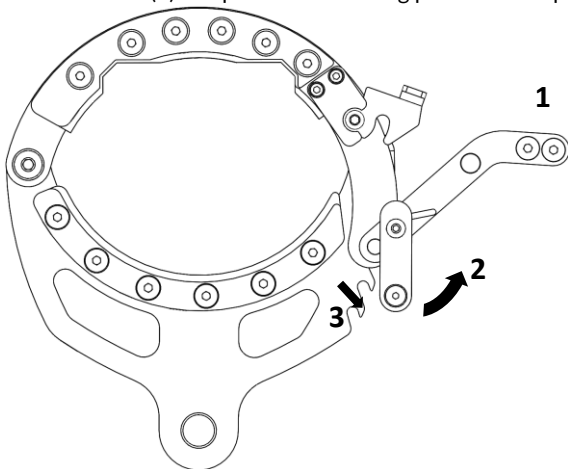

Fig. 8 Releasing the hook clamp

Grab the device with your right hand, holding the fixed jaw and the locking lever. Pull out the moving jaw with the pinion (1) out of the fixed jaw, thus opening the hook clamp.

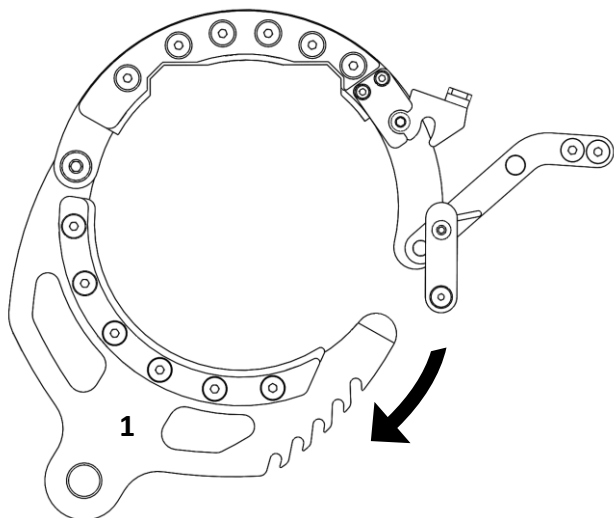

Fig. 9 Opening the hook clamp

Place the open clamp around the vertical support.

- If using on a square shaped profile, adjust the position to align the profile with the inner cutouts on the clamp.
- If using on a round profile, place the inner surface of the fixed jaw onto the vertical support on the opposite side from yourself.

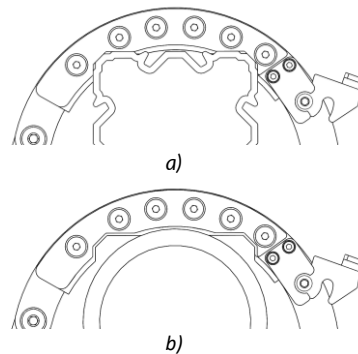

Fig. 10: Placing the HAWP_L on a vertical support: a) square; b) rectangular

Hold the device in place and then close it, sliding the moving jaw with the pinion into the fixed jaw, so that both fit snugly to the vertical support and the hook clamp is positioned horizontally.

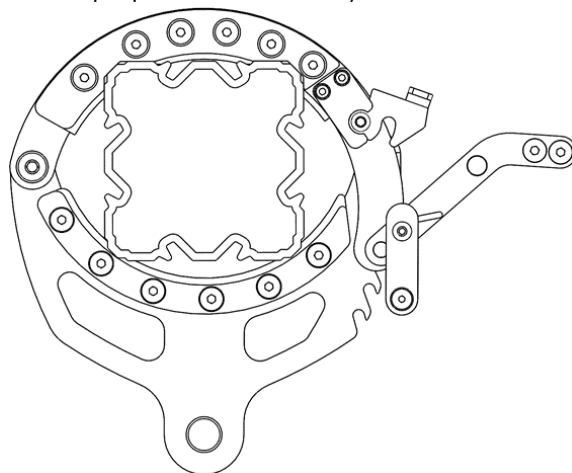

Fig. 11 Closing the HAWP

Hold the device in place and then move the locking lever (1) towards yourself, so that the locking pin on the shorter arm of the lever can be pushed into the slot on the pinion.

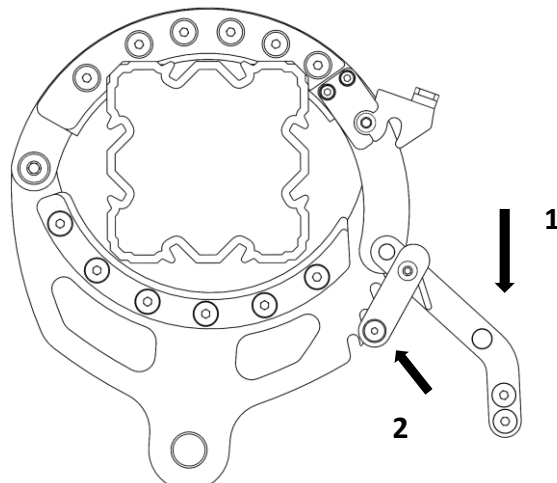

Fig. 12 Placing the pin in the pinion

After pushing the locking pin into the pinion, lock the device by sliding the locking lever away from yourself (1) and towards the body of the device.

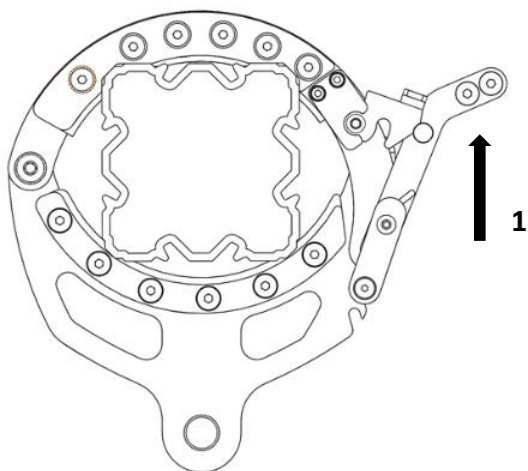

Fig. 13 Locking the lever

Make sure that the spring-powered hook has locked the lever.

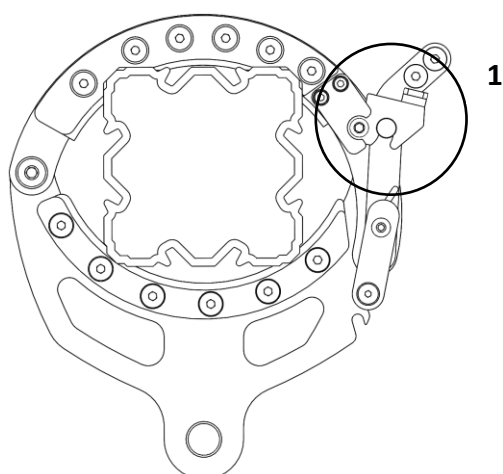

Fig. 14 Securing the lever with the hook

Note:
If the locking lever is not deployed correctly, the hook clamp can open, thus providing no belay!

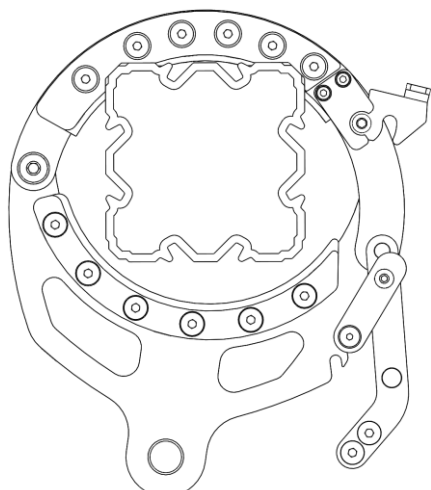

Fig. 15 Locking lever not deployed correctly, providing no belay

Scope of use and using the HAWP_S

The small hook clamp for scaffolding towers (HAWP_S) is designed for use on scaffolding towers with small diameter supports and standard scaffold tubes with a diameter of 48,3 mm.

The HAWP_S hook clamps are installed on the supports in exactly the same way as the HAWP_L variant.

To place a HAWP_S hook clamp on a tube support or a vertical scaffold tube, proceed as follows:

1. Unlock the locking lever.

NOTE:

The latching hook is inside the locking lever and has to be operated manually!

2. Release the locking lever.
3. Slide the locking pin out of the pinion
4. Open the device by spreading its jaws
5. Place the hook clamp around the round tube
6. Close the device – push the jaws together
7. Pull back the locking lever and push the locking pin into the pinion.
8. Lock by turning the lever upwards
9. Lock the lever manually or check if it has been locked by the latching hook.

HAWP_S hook clamps are B type anchoring devices for creating anchor points on vertical scaffolding tower supports or scaffold tubes to provide belay for a user.

The manufacturer has also approved them for setting up short temporary horizontal lifelines.

To set up such a lifeline, connect two hook clamps sitting at the same level on two different vertical supports using a piece of rope or tape such as fineline.

Belaying with HAWP_L

Commence climbing on a scaffolding tower by placing the first HAWP_L hook clamp connected to a fall arrest lanyard as high as possible above the belaying point on the harness.

It is possible to connect the fall absorbing lanyard to the harness both at the dorsal as well as the sternal point – this depends on the user's preference.

While climbing on the scaffolding tower, change the position of the HAWP_L hook clamps on the vertical support sections in a way that allows for continuous belay.

Always place the HAWP_L hook clamps as high as possible on the vertical support, so that the lower attachment point is never below the belaying point on the user's harness. This ensures the correct fall factor value at all times and, as a result, a reduction in the load placed on the user during a potential fall.

Make sure each time that the locking pin is placed in the pinion and the locking lever is secured with the latching hook.

Important note:

Always remember to load the HAWP hook clamps in the vertical axis, with the force applied downwards.

ANCHOR HOOK CLAMP FOR SCAFFOLDING TOWERS - WARRANTY CARD

THANK YOU FOR PURCHASING A ROCK MASTER PRODUCT

Congratulations on the purchase of your new equipment. Please remember that to enjoy it safely and for a long time it is crucial to use it correctly, according to its design and purpose.

Should you need to use services covered by the warranty, please get in touch directly with the manufacturer or with a customer service and/or repair shop authorized by the manufacturer.

Before reaching out for service, please read the manual carefully.

DEVICE NAME:

TYPE:

SERIAL NUMBER:

MANUFACTURED BY:



DATE OF MANUFACTURE:

DATE OF PURCHASE:

WARRANTY PERIOD

12 months from purchase, until:

WARRANTY CONDITIONS

1. Rock Master sp. z o. o. sp. k. provides a 12 month warranty for the correct function of the device, starting from purchase.
2. The warranty only covers manufacturing faults.
3. Any fault discovered should be reported to the manufacturer or to a customer service and/or repair shop authorized by the manufacturer.
4. The manufacturer guarantees that any faults discovered during the warranty period will be checked at no cost and removed at no cost within 14 or 21 days since they were reported. The warranty period is extended by the time needed for repairs.
5. In case of any complaints, it is only possible to replace the faulty product if the repairs undertaken are unsuccessful and the manufacturer deems the product impossible to repair.
6. The warranty card is only valid together with proof of purchase and is the only basis for any warranty service.
7. When purchasing, you declare to have read and accepted the warranty conditions.

NOT COVERED BY THE WARRANTY

1. The product is to be used only as designed, any other use is not covered by the warranty.
2. Any repairs by unauthorized persons, tampering or modifications void the warranty.
3. Any normal wear and tear (scrapes, scratches, slight chafing of the protective or decorative coating) is not covered by the warranty.
4. The warranty does not cover normal maintenance work required for the device to function properly or inspections necessary during the warranty period.

REPAIRS

DATE OF REPORT	DATE OF REPAIRS	REPAIRS UNDERTAKEN AND/OR PARTS REPLACED	SERVICE CENTRE - SIGNATURE AND STAMP

Address:
Krolewska 94/11
30 - 079 Krakow



Contact us on:
office@rockmaster.eu
+48 12 290 30 35

ANCHOR HOOK CLAMP FOR SCAFFOLDING TOWERS – LOGBOOK

The owner and sole user of the equipment is responsible for keeping to logbook updated and complete. Before the equipment is first issued, the logbook should be completed by the person responsible for stock keeping with all necessary information in regard to the equipment (name, type, serial number, date of purchase, catalogue number, the manufacturer's name). Information on periodic inspections is entered by the manufacturer or their authorized representative.

NOTE:

It is forbidden to use any PPE for which no logbook is present or is incomplete.

DEVICE NAME:	
TYPE:	SERIAL NUMBER:
MANUFACTURED BY:  ROCK MASTER SAFE WORK AT HEIGHT	
DATE OF MANUFACTURE:	FIRST USED ON:
DATE OF PURCHASE:	LAST USED ON:

INSPECTION AND REPAIR HISTORY

NUMBER	DATE	REASON	RESULT	DATE OF THE NEXT INSPECTION	INSPECTION CARRIED OUT BY (SIGNATURE)
1					
2					
3					
4					
5					
6					
7					
8					
9					
10					